

## APPENDIX A



### SECTION I

## OBJECTIVES AND GENERAL APPLICANT INFORMATION

## SECTION I

### Federal and State Program Objectives

The Community Development Block Grant (CDBG) Program was established by the federal Housing and Community Development Act of 1974 (Act). Administered nationally by the U.S. Department of Housing and Urban Development (HUD), the Act combined eight existing categorical programs into a single block grant program. In 1981, Congress amended the Act to allow states to directly administer the block grant for small cities. At the designation of the Governor, the Department of Commerce and Economic Opportunity (Department) assumed operation of the State of Illinois CDBG – Small Cities Program in the same year. Through this program, funds are available to assist Illinois communities to meet their greatest economic and community development needs, with an emphasis on helping persons of low-to-moderate income.

To ensure that the State-administered program meets the intent of the federal Housing and Community Development Act of 1974, as amended, Congress has required that state-administered programs meet at least one of the following three national objectives:

- ◆ Benefiting low-to-moderate income (LMI) persons; or
- ◆ Aiding in the prevention or elimination of slums and blight; or
- ◆ Meeting other community development needs that pose a serious and immediate threat to the health and welfare of the community.

To complement these federally-mandated objectives, the State has established the following specific objectives for the CDBG Program:

- ◆ Strengthen community economic development through the creation of jobs, stimulation of private investment and strengthening the tax base;
- ◆ Improve public infrastructure and eliminate conditions which are detrimental to health, safety and public welfare; and
- ◆ Conserve and expand the State's housing stock in order to provide a decent home and a suitable living environment for persons of low-to-moderate income and the developmentally disabled.

Within the statutory requirements of the Act, Illinois has the flexibility to design its own program objectives and procedures for program administration and to develop criteria for selection of grant recipients. CDBG offers a variety of financial assistance programs which have been designed to meet locally defined community needs.

## GENERAL APPLICANT INFORMATION

### A. FUNDING AVAILABILITY

The State's 2024 Community Development Block Grant allocation from the U.S. Department of Housing and Urban Development (HUD) was \$29,464,578 and is being used as the basis for funding below. The amount of CDBG funding for Program Year 2025 will not be determined until Congress passes the budget. We anticipate the 2025 budgets for Public Infrastructure, Housing Rehabilitation and Economic Development to be within 5% of the amounts allocated in 2024.

HUD regulations provide that three percent (3%) of the allocation plus \$100,000 can be used for administration and technical assistance for the State-administered program. In case of unforeseen circumstances, the Department reserves the right to adjust allocations to address specific needs to benefit Illinois' non-entitlement communities.

Each program component has a maximum funding level or grant ceiling. While grant ceilings establish the upper limits that may be requested, individual grants are invited only in amounts commensurate with requirements of the proposed project.

The Department has established a minimum grant award level of \$300,000 for all programs with the exception of Disaster Response. Applications for less than the minimum grant will not be accepted.

Fund availability from the 2025 allocation will be distributed as follows:

<u>Program Category</u>	<u>Budget</u>	<u>Grant Ceiling</u>	<u>Application Dates</u>
<b><u>Competitive Programs</u></b>			
Public Infrastructure (PI)	<b>\$19,500,000</b>	\$1,000,000	12/4/24
Housing Rehabilitation (HR)	<b>\$7,000,000</b>	\$650,000	12/4/24
<b><u>Ongoing (non-competitive) Programs</u></b>			
Economic Development (ED)	<b>\$1,980,641</b>	\$1,000,000	<i>Rolling</i>
Disaster Response (DR)	<b>\$0.00</b>	\$250,000	<i>NA</i>

Although no funds are specifically allocated for the Disaster Response program, the Department will adjust allocations if a need arises

**B. ELIGIBLE APPLICANTS**

Only units of general local government (i.e., cities, villages, townships and counties) may apply for funding. Municipalities must not be a HUD direct Entitlement community or be located in an urban county that receives "entitlement" funds. **County and township applicants should not include areas that are incorporated within a city or village.** Incorporated areas **must** apply on their own behalf, regardless of whether a water district or sanitary district is involved. Only units of local government recognized by the Illinois Constitution and able to support economic development activities on a sufficient scale are eligible to apply for Economic Development grant funding. This includes cities, villages, and counties.

**Units of local government may apply for one grant per competitive program per year. Applicants that received a grant in the previous year must demonstrate reasonable progress by the time the application is reviewed, or it will not be considered.** Applications that further a project in progress, whether funded with or without CDBG funds, will not be accepted.

All applicants must be registered in the Grant Accountability and Transparency Act system (GATA) and be prequalified on the GATA Portal at <https://gata.illinois.gov> on the application due date. Applications submitted by communities who are not prequalified **will not be considered for review.** For more information on GATA Prequalification and other Grantee resources, visit <https://dceo.illinois.gov/aboutdceo/grantopportunities/learning-library.html>.

**C. INELIGIBLE COMMUNITIES**

Communities receiving an annual allocation directly from HUD on an entitlement (formula) basis are not eligible to apply for the State’s CDBG funding. In 2025, Illinois has 33 metropolitan cities and eight urban counties named as Entitlements. They are:

**Urban Counties\***

Cook County	Madison County
DuPage County	McHenry County
Kane County	St. Clair County
Lake County	Will County

**Metropolitan Cities**

Arlington Heights	DeKalb	Mount Prospect	Rantoul
Aurora	Des Plaines	Naperville	Rockford
Berwyn	Elgin	Normal	Rock Island
Bloomington	Evanston	Oak Lawn	Schaumburg
Champaign	Hoffman Estates	Oak Park	Skokie
Chicago	Joliet	Palatine	Springfield
Cicero	Kankakee	Pekin	Urbana
Danville	Moline	Peoria	Waukegan
Decatur			

\*Some local governments within Urban Counties have opted out of the County Entitlement. Those communities are eligible for the State-Administered program upon furnishing documentation of the opt-out.

**D. APPLICATION MATERIALS**

**All original Application Forms and Materials as shown in the Guidebook must be utilized.** The Department WILL designate an application “DO NOT FUND”, and not complete the rest of its’ scoring for the following reasons:

- ◆ Using self-created forms;
- ◆ Adding to or removing any language in forms.
- ◆ Forged, copied, taped, pasted or any alterations to original signatures or dates;

All Letters, Notices, Resolutions, Agreements or other communication provided by the unit of local government as part of the application must be of the exact verbiage contained in the Guidebook, be on the applicant community’s official letterhead and have original signatures where required.

All application forms and certifications requiring signature must be signed by the Chief Elected Official of the applicant community, unless otherwise noted.

**E. TECHNICAL ASSISTANCE**

If you have any questions concerning the application process, please call the Department at (217) 558-4222 or contact the CDBG Grant Manager for your program and area.

*This page intentionally left blank*



## SECTION II

# CDBG PROGRAM INFORMATION AND POLICIES

## SECTION II

### CDBG PROGRAM INFORMATION AND POLICIES

This section of the application guide contains a description of the general requirements and policies applicable to all CDBG projects.

#### A. REQUIREMENTS AND DISCLAIMERS

The following requirements and disclaimers apply to all applications submitted for consideration under the CDBG Program.

1. Costs previously incurred (such as design) as well as costs incurred in preparation of applications and local income surveys are not reimbursable under this grant program.
2. The Department reserves the right to reject any or all applications received and/or negotiate or cancel in part or in entirety grants resulting from application awards if it is in the Department's best interest to do so.
3. **The Department reserves the right to withdraw a commitment for CDBG funds where special grant conditions have not been satisfied within 90 days after the date of the Notice of State Award Finalist**, or at the discretion of the Department if it is determined the project will not progress.
4. The Department reserves the right to establish the amount of grant funds awarded, raise the individual grant ceilings, and to shift funds from one CDBG component funding area to another. The Department further reserves the right to award funds to the next highest rated applicant(s) for any component should funds become available due to de-obligations, etc.
5. The Department reserves the right to deny funding when submitted applications involve eligible units of government with serious unresolved monitoring or audit findings related to performance. In addition, funding will be withdrawn for any applicant or awardee that has not completed required audits and has been FEIN locked subsequent to the award but prior to grant agreement execution.
6. On an annual basis, the Department will re-evaluate the timely distribution of funds under all program components, as well as the availability of unspent and recaptured funds. Unspent and recaptured funds will be awarded to fund additional CDBG-eligible projects. Depending upon available funds, a Back-up Funding round may be implemented later in the program year.
7. The Department reserves the right to not fund applications that address problems which obviously are a result of deferred maintenance.
8. The Department reserves the right to consider an outside technical review by an appropriate agency or agencies. The Illinois Environmental Protection Agency, the Illinois Department of Public Health, and/or USDA Rural Development may be asked to review public infrastructure projects involving water or sewer activities.
9. Any additional non-CDBG resources must be firmly committed. Also, it must be evident in the application that both CDBG and non-CDBG funds will address the same need.



10. A grant agreement will be issued for a contract period of twenty-four months for Public Infrastructure, Housing Rehabilitation and Economic Development grants. All projects must be operational at the end of the twenty-four-month grant term. No more than one twelve-month extension may be considered.
11. Proposed projects (including the fund source, cost estimates, benefit, urgency, project area, and/or construction activities) supplied in the grant application submitted for funding must not be changed or modified prior to grant award or at the time the project is bid. If extenuating circumstances exist, the Grantee may submit a modification request after the receipt of its executed Grant Agreement.
12. Requests for Modifications must be presented to the Department prior to any changes being made to the project area, beneficiaries, cost estimates, or funded activities. All modifications must include only original and environmentally-cleared project location(s). Requests for activities outside the original project location(s) will not be considered. Modifications that will decrease the benefit to low-to-moderate income persons will not be considered. Modifications to decrease or increase the scope of work due to greater than or less than estimated costs will not be considered.
13. The use of in-kind services as additional funding is limited. Applicants must identify the specific tasks/services that will be performed or provided. Each task/service must be quantified by outlining the number of personnel assigned to the task and current payroll status; number of hours; and the hourly rate. Additionally, the qualifications of each individual to perform the assigned task/service (e.g., construction inspection) must be provided. If in-kind services are being utilized, a local council resolution must be included in the application.
14. Local governments may not assess any fees against property "occupied" by eligible low-to-moderate income persons. The most common type of assessment is a connection fee, which is a one-time charge made as a condition of access to an improvement -- normally a sanitary sewage collection or water distribution system.
15. **With the exception of the Exempt-CENST-ER-Format form, and only if CDBG funded Activity Delivery and/or Rehabilitation Administration is budgeted, no environmental review activities can take place until the applicant has received the Notice of State Award Finalist.** Once this Notice is received, only then may the grantee initiate required environmental clearance requests with the four State environmental clearance agencies and federal environmental sources, in accordance with Federal NEPA requirements and State law. **DO NOT** reuse State environmental clearance letters previously obtained for another funding source. In certain circumstances, the CDBG Economic Development Program Manager may allow a community to begin the Environmental review early.
16. In accordance with the Interagency Wetland Policy Act of 1989, an applicant whose proposed project site is located on or within 250 feet of a wetland site listed on the National Wetlands Inventory will be required to comply with the requirements of the Act. This includes: developing a plan to minimize adverse impacts on wetlands, or providing written evidence that the proposed project will not have an adverse impact on a wetland. Project must also comply with Federal Wetlands Protection regulations at 24-CFR 58.5(b)(2) and Executive Order 11990, which may require preparation of an Eight-Step Wetlands Review.

17. A FEMA issued Floodplain Map must be included in the application. You can obtain this map by calling FEMA at 1(800) 358-9616 or by using their website: <https://msc.fema.gov>. Exact project location(s) must be clearly drawn on the FEMA map prior to submission. The most current version available on <https://msc.fema.gov> must be used.
18. CDBG grant funds may not be used for any activity in an area delineated as a special flood hazard area in FEMA's most current flood advisory maps unless it also ensures that the action is designed or modified to minimize harm to or within the floodplain in accordance with Executive Order 11988, 24 CFR 55, and (eff. 6/24/24) HUD Federal Flood Risk Management Standard "(FFRMS). In accordance with 24 CFR 55, CDBG grant funds must not be committed in a FEMA-designated floodway, unless the project is a functionally dependent use of the floodway, as approved by the Department ahead of time, Under HUD FFRMS, CDBG assistance committed for any Critical Action (e.g., for PI, water or sewer plant, or water tower) in a FFRMS flood plain must be mitigated through elevation.

## B. STATE AND FEDERAL COMPLIANCE AREAS

Each applicant must agree to comply with all applicable federal and state requirements. **This includes 2 CFR 200, 24 CFR 570, Part 85, and the Grantee Accountability & Transparency Act (GATA).** These can have a significant impact on the costs and complexity of a project. Applicants who receive a grant award will be expected to submit signed assurances that they will comply with all federal mandates. Some areas which applicants must comply with include:

1. The National Environmental Policy Act (NEPA) which establishes procedures for protecting the environment. In order to use the CDBG funds awarded to a local government, the grantee has to comply with environmental procedures, standards and guidelines mandated by NEPA and all other applicable environmental regulations (e.g., prime farmland protection, historic preservation, floodplain hazards, etc.).
2. The Interagency Wetland Policy Act of 1989 requires applicants to certify that the proposed project is compatible with established State of Illinois policy regarding wetlands (i.e., to minimize the destruction of existing wetlands in Illinois as a result of State and State-supported activity). The Federal Wetlands Protection regulations at 24 CFR 58.5(b)(2), Executive Order 11990 and HUD FFRMS also apply.
3. The Illinois Endangered Species Protection Act and the Illinois Natural Area Preservation Act & Federal Endangered Species Act of 1973 Compliance requires consultation with the Endangered Species Consultation Program of the Illinois Department of Natural Resources to assure compliance. The consultation process must be implemented to avoid or minimize adverse impacts to State-listed species and their essential habitats that may result from the actions of state and local units of government. Applicants must certify the completion of the consultation process, as well as Federal Endangered Species Compliance under 24 CFR 58.5(e). This process can be initiated through the U.S. Fish & Wildlife Service Endangered Species website (<https://www.fws.gov/endangered/>).
4. The Davis-Bacon Prevailing Wage Act requires the payment of prevailing wages for all construction funded in whole or in part with federal funds, including funds passed through to private firms. If your project involves construction and/or equipment installation, go to

- <https://dceo.illinois.gov/communitydevelopment/davisbaconresources.html> for information concerning the applicability of federal labor standards.
5. The Uniform Relocation Assistance and Real Property Acquisition Policies Act of 1987 applies to federally assisted activities that involve the acquisition of real property or the displacement of persons, including displacement caused by rehabilitation and demolition activities. Any person or business displaced as a direct result of federal assistance must be provided with Uniform Relocation benefits.
  6. Equal Opportunity and Fair Housing Accessibility Laws require that CDBG grantees administer their project in a manner that affirmatively furthers equal opportunity and fair housing. All CDBG grantees will be required to undertake specific activities to further fair housing. CDBG grantees must assure all activities and services are accessible to persons with disabilities.
  7. Section 3 under the Housing and Urban Development Act of 1968 requires recipients to give, to the greatest extent feasible and consistent with the existing federal, state, and local laws and regulations, job training, employment, contracting and other economic opportunities to Section 3 residents and Section 3 business concerns. For more information on Section 3, please see <https://dceo.illinois.gov/communitydevelopment/section3.html>
  8. The National Emission Standards for Hazardous Air Pollutants (NESHAP) of the U.S. Clean Air Act assures that, when existing buildings are demolished and/or renovated, people outside of those buildings (i.e., passers-by or neighborhood residents) are protected from airborne asbestos. If asbestos materials are involved in the rehabilitation work, the applicant must contact the Field Operations Section, Bureau of Air of the Illinois Environmental Protection Agency to ensure compliance with Asbestos NESHAP.
  9. Build America Buy America Standards set forth in the Infrastructure Investment and Jobs Act. The Grantee must comply with the requirements of the Build America, Buy America (BABA) Act, 41 USC 8301 note, and all applicable rules and notices, as may be amended, if applicable to the Grantee's infrastructure project. Pursuant to HUD's Notice, "Public Interest Phased Implementation Waiver for FY 2022 and 2023 of Build America, Buy America Provisions as Applied to Recipients of HUD Federal Financial Assistance" (88 FR 17001), any funds obligated by HUD on or after the applicable listed effective dates, are subject to BABA requirements, unless excepted by a waiver. BABA does not apply to the Housing Rehabilitation program.

## C. CITIZEN PARTICIPATION

**If the publication guideline or public hearing requirements are not met, the application will not be reviewed further nor considered for funding.**

**A public hearing must be held prior to submission of an application and prior to passage of a local council resolution of support by the local governing body.**

### Public Participation

- ◆ All applicants must provide for public participation. All citizens must be given reasonable access to the community's application and reasonable time to review the application prior to the public hearing.

### Public Notice

- ◆ A Notice of Public Hearing must be published at least once in a newspaper of general circulation at least seven calendar days (excluding the date of publication *and* excluding the date of the hearing) prior to the public hearing.
- ◆ The Notice of Public Hearing must include the address of where project information is available for viewing.
- ◆ All project information must be available for viewing on the first business day (not Saturday, Sunday, a holiday, or day the office is not open) after date of publication at an easily accessible location within the community applying for the grant.
- ◆ The Public Comment Period must coincide with the time period between Notice and Hearing; concluding after the Hearing has been completed. The address for submission of written comments must be included in the Public Notice.

### Conducting the Public Hearing

- ◆ Public Hearings must be facilitated by the applicant's governing body chief elected official or authorized official and certified by the chief elected official, authorized official or clerk.
- ◆ Efforts must be made to assure reasonable access to the public hearing by persons with disabilities; as well as be conducted in a manner to meet the needs of non-English speaking residents where a significant number of non-English speaking residents can reasonably be expected to participate.
- ◆ Those attending the public hearing must be informed of where and how to access the applicant's CDBG records.
- ◆ The Hearing must allow for public comments on the application and project.
- ◆ A sign-in sheet must be provided to document attendance. It is suggested that each person attending the public hearing provide his address and identify his role of participation (e.g., citizen, elected or appointed official, municipal employee, contractor, grant writer or administrator, business owner, etc.).
- ◆ The public hearing must cover:
  1. The amount of funds available;
  2. The project activities that will be undertaken with CDBG funding, including amount;
  3. The project activities that will be undertaken with additional project funding, including amount;
  4. The estimated amount proposed for activities that will benefit LMI individuals;
  5. Plans for minimizing displacement as a result of the CDBG grant-assisted activities and to assist persons actually displaced, if applicable;
  6. A detailed, prioritized list of community development and housing needs; and
  7. A narrative discussion of the scope of the project including the proposed improvements, costs, benefit area, impact on community finances, etc.
- ◆ The minutes of the public hearing must be certified by the chief elected official or other authorized local officials, such as county clerk, city clerk, etc.

- ◆ Following the Public Hearing, a Resolution of Support from the local governing body must be passed that authorizes the local government to apply for funds. The date of the Resolution must be on or after the date of the Public Hearing.

Documenting Citizen Participation

The following documents verifying 7-day notice and citizen participation must be submitted with the application.

- ◆ Complete Newspaper Clipping of Notice of Public Hearing that contains all published verbiage
- ◆ Publisher’s Certification (cannot be an e-mail)
- ◆ Certified Minutes
- ◆ Attendance Sheet, (original sign-in sheet; not type-written, not roll call from minutes)

**If the publication guideline or public hearing requirements are not met, the application will not be reviewed further nor considered for funding.**

**A public hearing notice template is contained in Section VII.**

Please use the following calendar as a guide to timing of Citizen Participation activities:

November 2024						
Sun	Mon	Tue	Wed	Thu	Fri	Sat
			1	2	3	4
5	6	7	8 Public Hearing Notice Published	9 Application Materials available to Public	10	11
12	13	14	15	16 Public Hearing	17	18
19	20	21	22	23 Thanksgiving	24	25
26	27	28	29	30		

**D. ACTIVITY DELIVERY COSTS and ASSOCIATED COSTS**

Community Development Block Grants are federally funded and must comply with extensive federal regulations including procurement, environmental, Davis-Bacon labor standards and others. Failure to comply could result in grant funds being repaid by the Grantee/Community. It is important that Grantees seek out an experienced Grant Administrator to manage all the details of the grant, provide oversight and coordination of the project. This management process is called “Activity Delivery”.

**All grant administrators (it is assumed the administrator is writing the grant) must attend both the 2025 Application Workshop and the 2024 Grant Administrator's Workshop to be held October 1st & 2nd, 2024.**

**All Grantees must use an experienced Environmental specialist, who has completed at least one Illinois CDBG Environmental Record Review since January 1, 2018 OR has successfully completed DCEO Environmental Training conducted on July 18, 2018.**

**The Administrating Entity must be named in the application.** Contracts for the purpose of securing services for activity delivery and/or rehabilitation administration (Inspector) must be competitively procured under 2 CFR 200 prior to application unless the contract is with an Intergovernmental Agreement Agency or an Inter-Entity Agreement Agency. The grantee's procurement process must be documented and kept with the grant files. **All contracts for provision of Activity Delivery and/or Rehabilitation Administration (Inspector) must be provided to DCEO with the application, regardless of whether Activity Delivery is paid from grant funds or local government funds. In addition, if Activity Delivery is procured and paid by grant funds, a completed Exempt-CENST-ER-Format form must be included with the application.**

The maximum amount of CDBG funds that may be allowed for reasonable activity delivery costs is \$35,000. Activity delivery costs above that amount must be contracted separately and not included in the application. If paid with CDBG funds, activity delivery costs must be included in the total grant award.

**Activity Delivery:** Includes such costs as (but are not limited to) salaries, travel costs, services performed under third party contracts, including legal and audit services, environmental record review preparation, additional fidelity bonding costs or other services required for the delivery of grant activities. For Housing Rehabilitation, Activity Delivery is to be used for administrative services necessary to the delivery/completion of the CDBG housing rehabilitation project.

Activity delivery costs may include the estimated cost of an audit to be conducted in accordance with the Comptroller General's Governmental Auditing Standards, and 2 CFR 200.501, if applicable. However, be advised that CDBG funds can only be used to pay for its portion of the costs of an audit when a "single audit" is required. If a grantee expends less than \$750,000 of federal funds in one fiscal year, a single audit is not required. The grantee may still have to conduct an annual audit as required by State statute, but CDBG funds may not be used to pay for any portion of the audit costs. For more information on audit standards, please see:

<https://www.ilga.gov/commission/jcar/admincode/044/044070000A00900R.html>

All Activity Delivery costs must be substantiated with complete invoices utilizing the template provided by the Department. Invoices without sufficient detail will not be paid.

In addition to Activity Delivery, recipients of Housing Rehabilitation grants may utilize grant funds to pay for Rehabilitation Administration (inspection) based on a pre-determined scale set by the Department (see below).

Rehabilitation Administration covers all delivery costs (including staff, other direct costs, and service costs) directly related to carrying out housing rehabilitation activities. Examples include appraisal, architectural, engineering, and other professional services; preparation of work specifications and work

write-ups; loan processing; survey, site and utility plans; application processing; and other fees. Rehabilitation Administration costs must be substantiated with complete invoices.

8 Homes	\$34,000
9 Homes	\$36,000
10 or more Homes	\$38,000

#### E. **INITIAL GRANTEE RESPONSIBILITY**

Successful applicants will receive a **Notice of State Award Finalist (NOSAF)** specifying terms and conditions of the grant. This will include completion of Environmentals (including “before” pictures for Tier II Housing Rehabilitation projects), clearance of special conditions resulting from the application review, and acknowledgement letters to the locality’s federal-level Senators and Representative.

**GRANTEES MUST COMPLETE ALL REQUIREMENTS IDENTIFIED ON THE NOTICE OF STATE AWARD FINALIST (NOSAF) WITHIN 90 DAYS OF THE NOSAF DATE. If not completed, the Chief Elected Official and Grant Administrator will be notified and a two-week extension provided. FAILURE TO COMPLETE OUTSTANDING REQUIREMENTS WITHIN 104 DAYS OF THE NOSAF DATE WILL RESULT IN FORFEITURE OF THE GRANT AWARD.**

DCEO will hold a mandatory Grant Administration Workshop after Awards are announced. All Administrators assigned to an awarded grant are required to attend.

Once terms are accepted, and the conditions met, the Grantee will receive a **Notice of State Award (NOSA)** which includes information regarding your entity, grant funding, grant terms and conditions, and specific conditions assigned to the grant based on the risk assessments. In order to receive the formal Grant Agreement, the Grantee must indicate agreement to the contents of the NOSA by remitting its acceptance through Grantee Portal (<https://grants.illinois.gov/portal>).

After the Grantee has submitted all applicable documents, they will receive a formal **Grant Agreement** with further instructions. Grantees will be expected to sign and return the agreement within 30 days for formal execution by the Department.

*This page intentionally left blank*





## SECTION III

# COMPETITIVE PUBLIC INFRASTRUCTURE COMPONENT

## SECTION III

### **FUNDING OPPORTUNITY INFORMATION**

This Application is for the use of federal Community Development Block Grant (CDBG) Funds through the State of Illinois' Department of Commerce and Economic Opportunity (DCEO), Office of Community Development.

CATALOG OF FEDERAL DOMESTIC ASSISTANCE (CFDA) NUMBER: 14.228

CFDA TITLE: COMMUNITY DEVELOPMENT BLOCK GRANTS/STATES PROGRAM

CATALOG OF STATE FINANCIAL ASSISTANCE (CSFA) NUMBER: 420-75-1632

CSFA TITLE: COMMUNITY DEVELOPMENT BLOCK GRANTS  
PUBLIC INFRASTRUCTURE PROGRAM

DCEO FUNDING OPPORTUNITY NUMBER: 24-2

DCEO FUNDING OPPORTUNITY TITLE: CDBG PUBLIC INFRASTRUCTURE PROGRAM

Applications may be submitted based on the published Notice of Funding Opportunity and 2025 Guidebook. The Guidebook and required supporting documentation for the application can be found at: <https://dceo.illinois.gov/communitydevelopment.html> **Sections I, II and VII apply to all program elements. Please be certain to review these sections as well as the specific programmatic section of the Guidebook.**

### ***COMPETITIVE PUBLIC INFRASTRUCTURE PROGRAM***

The Department has estimated \$19,500,000 in CDBG funds will be available for the Public Infrastructure (PI) component. A grant ceiling of \$1,000,000 per project, including allowable Activity Delivery costs up to \$35,000 for all projects, has been established. The objective of this program component is to fund public infrastructure projects with priority given to projects involving water and sanitary sewer systems, or storm sewer upgrades or combined sewer separations.

Applications for the Competitive PI component will be due **Wednesday, December 4, 2024**. (See [Submission Information](#), Section III, Part I.)

In a situation where two or more eligible local governments face a common problem, a joint application may be filed. See Section VII for an intergovernmental cooperation agreement. Local governments, however, must not only share a common problem, but must be able to demonstrate that a joint effort is required to solve the problem. Include this information in the Project Summary. Joint applications which are submitted only for administrative convenience will not be accepted.

**“On Behalf Of” Applications:** Cities, Villages, Counties, and Townships may also submit "on behalf of" applications for local entities that otherwise may not be eligible to apply; for example, rural water system or cooperative, water or sanitary district, or an unincorporated area. .

1. The entire project area must be contained within the unit of local government submitting the “on behalf of” application.
2. No more than one (1) “on behalf of” application may be submitted in the same county for the same Public Utility, System, Cooperative or District.

3. An "on behalf of" or joint application may not be filed for an entitlement municipality or a municipality located in an entitlement county.
4. If applying "on behalf of", the Public Utility, System, Cooperative or District must be indicated in the Transmittal Letter.
5. The Public Utility, System, Cooperative or District that the application is on behalf of must be included in the Project Summary.
6. For applications submitted on behalf of a Public Utility, System, Cooperative, or District, (where the awarded grant funds will be passed-thru to the cooperative or district for the completion of project activities) the applicant will be required to enter into a Participation Agreement or what is commonly known as a "claw back agreement" with the district/cooperative regarding the specific CDBG project activities, and the applicable sanctions that may be applied if those objectives are not satisfied. Participation Agreements will be completed after the Department issues a Notice of State Award Finalist (NOSAF), which contains conditions related to the grant.

#### A. **ELIGIBLE ACTIVITIES**

The funding priority for the PI component is for water and sanitary sewer systems, and storm sewer construction projects, including combined sewer separations. **Activity Delivery for administrative activities up to \$35,000 is eligible for funding.** See Section II, Part D for specifics on Activity Delivery. All grant funds must relate to one of the following HUD-defined activity codes:

**03I Flood and Drainage Improvements** 24 CFR 570.201(c) or 42 USC 5305(a)(2) Used for the acquisition, construction, or rehabilitation of flood drainage facilities, such as retention ponds or catch basins. **Do not use 03I for construction/rehabilitation/separation of storm sewers, street drains, or storm drains: use 03Js for those.**

**03Jw Water Improvements** 24 CFR 570.201(c) or 42 USC 5305(a)(2) Used for the installation, replacement, or re-lining of water lines and fire hydrants (fire hydrants are only eligible when part of a larger project). Costs of street repairs (usually repaving) or sewer re-location made necessary by water improvement activities are eligible.

**03Js Sewer Improvements** 24 CFR 570.201(c) or 42 USC 5305(a)(2) Used for the installation, replacement, re-lining or separation of sanitary sewers and storm sewers. Costs of street repairs (usually repaving) or water main re-location made necessary by sewer improvement activities are eligible.

Activities must be germane, connected in purpose, address the same threat to health and safety, and have the same LMI benefit (project outcome). The Department will not accept applications for projects that have both a community-wide and a project-area benefit (e.g., water tower & water main replacement in same grant application) or that have multiple activity codes (e.g., water improvements and sewer improvements) in the same application.

For infrastructure projects involving alterations of streets, roads or highways which have pedestrian walkways, applicants must factor in the costs of adding and/or replacing curb ramps at all intersections having curbs or other barriers to entry from a street level or pedestrian walkway.

Funds may be used to finance costs associated with the connection of residential structures to public facility improvements. Residential structures which are "occupied" by eligible low-to-moderate income

persons must be connected. See the following diagram. A Connection is a privately-owned and maintained line on privately-owned property between a service lead/connection and a structure. **The limit that CDBG will pay for each individual water or sewer LMI household connection is \$6,000 per household.** If the Connection cost exceeds \$6,000 per household, the difference must be paid by other sources, but cannot be assessed against the low-to-moderate income occupant. **Applications for the sole or primary purpose of connecting low-to-moderate income households to public facility improvements will not be accepted.**

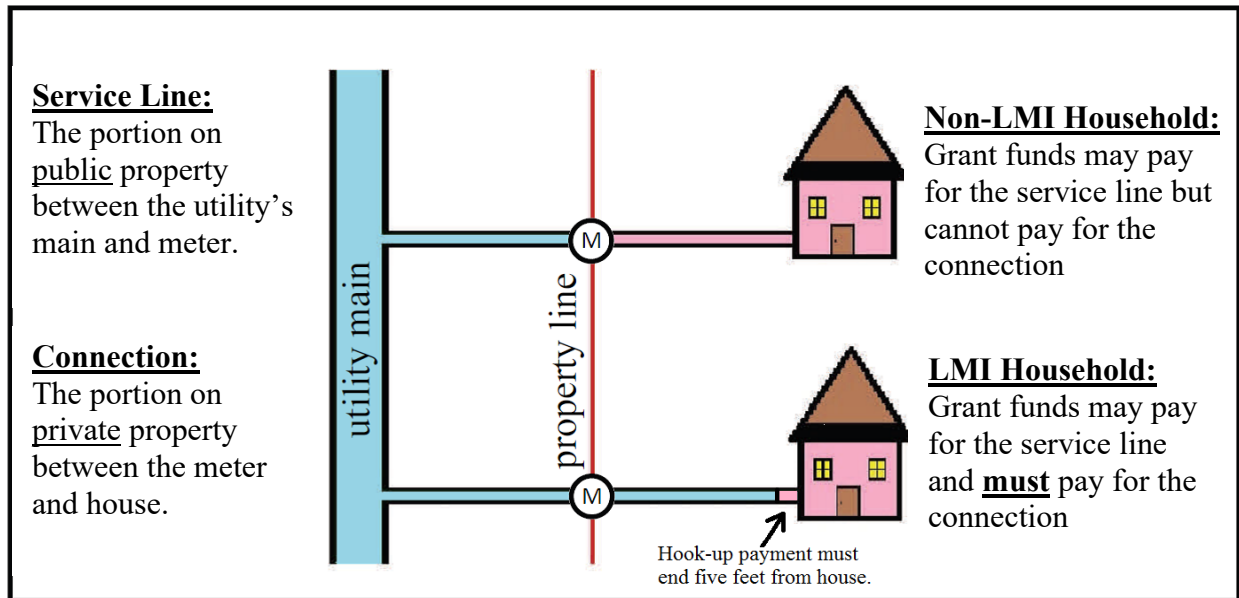

NOTE: Connections are considered a DIRECT BENEFIT activity. Therefore, prior to receipt of direct benefit, the applicant **MUST** document the income eligibility of each household receiving the grant-funded assistance through an Income Certification. **No projects only for the purpose of hook-ups, meters, fire hydrants, or curb stops/shut-offs will be accepted.**

Project areas must be primarily residential in character. Projects that are designed to benefit a commercial/business area will not be reviewed. The Department reserves the right to reduce a grant award's scope and/or funding to remove benefit to a non-residential area outlined in an application that otherwise primarily benefits a project area that is residential in character (e.g., remove proposed water main replacements in a commercial district, but fund those in adjacent residential neighborhoods).

- *The definition of primarily residential, provided by a federal source, is an area where the majority can be considered to contain residential real property. Under 12 CFR 1266.1, residential real property can be any of the following: one-to-four family property; multifamily property; real property to be improved by the construction of dwelling units; real property in the process of being improved by the construction of dwelling units.*
- *An area is not considered to be primarily residential if the majority of the defined area is non-residential. Under 12 CFR 1266.1, non-residential real property means real property not used for residential purposes, including businesses or industrial property, hotels, motels, churches, hospitals, educational and charitable institutions, clubs, lodges, association buildings, golf courses, recreational facilities, farm properties not containing a dwelling unit or similar types of properties.*

**B. INELIGIBLE ACTIVITIES**

The following are specifically identified as ineligible.

1. Construction of buildings, or portions thereof, used predominantly for the general conduct of government (e.g., city halls, courthouses, jails, police stations).
2. General government expenses. Costs of operating and maintaining public infrastructure and services (e.g., mowing parks, replacing street light bulbs).
3. Servicing or refinancing of existing debt.
4. Activities that do not address the threat to health & safety, including but not limited to:
  - a. projects designed for the sole purpose of replacing water meters;
  - b. projects designed for the sole purpose of addressing water loss;
  - c. portable generators;
  - d. permanently-affixed generators that are not part of a larger project;
  - e. telemetry systems and similar equipment that are not part of a larger project.
5. Projects needed as a result of deferred maintenance.
6. All Engineering costs associated with the planning, design or management of construction activities.
7. The following items when included as part of the Engineer's Cost Estimate:
  - a. Televising
  - b. Camera, Camera Work and/or Camering
  - c. Cleaning, Pre-Cleaning or Testing
  - d. Any word or phrase containing "Engineering"
  - e. Construction Management and Oversight
  - f. Construction Observation
  - g. Contingency or Contingencies
  - h. Miscellaneous, Misc., Miscellaneous Costs, and/or any phrase/word containing "Misc"
  - i. Other, Other Costs, Other Expenses and/or Other Construction (that is not defined on the Estimate)
  - j. Interest or Bond Costs
  - k. Inflation
  - l. Legal
  - m. Any other item or phrase not related to actual construction activities
  - n. Any construction item or phrase not related to construction activities spelled out in the Project Summary and Threat to Health/Safety Documentation (e.g., proposed sewer-relining project area is in SW side of community, but engineer's estimate includes sewer lift station rehab on east side of town, with no other documentation and/or explanation of how that relates to the SW side project)

## C. ELIGIBILITY THRESHOLDS

Projects determined to not meet the following three thresholds will be automatically designated as DO NOT FUND, and not reviewed further.

### 1. Low-to-Moderate Income Benefit Requirements

**Please Note: HUD is currently updating LMISD online and it is unknown when it will be available. If unavailable when application is submitted, you will need to use and we will verify eligibility via HUD's Dataset. A copy of this dataset is available on our website.**

Each application must include documentation that the proposed project will benefit at least 51.0 percent low-to-moderate income (LMI) persons. Those projects benefiting less than 51.0 percent LMI persons will not be considered for funding.

Each application must include documentation that any assessment levied against property (e.g., "tap-on" fee) occupied by low-to-moderate income persons will be waived or paid on behalf of the LMI households; and documentation that assistance to pay the cost of "connecting" (i.e., installing the privately owned and maintained line between a service lead/connection and a structure) will be offered to all residential households occupied by LMI persons.

**Municipalities, Townships, or Counties** proposing a project within their corporate boundaries must first attempt to determine its eligibility using HUD's Low-to-Moderate Income Summary Data (LMISD).

- LMI data for Illinois Places (city, village) can be found in the Library on the Office of Community Development webpage at <https://dceo.illinois.gov/communitydevelopment.html> or by using HUD's LMISD web-based application (linked to the next bullet-point).
- LMI Data for all areas (city, village, county, township, block group(s)) can be found using HUD's LMISD web-based application at <https://hud.maps.arcgis.com/apps/webappviewer/index.html?id=ffd0597e8af24f88b501b7e7f326bedd>.
- Information on how to determine LMI using HUD's LMISD and to access on-line tools, can be found at <https://www.hudexchange.info/programs/acs-low-mod-summary-data/>.

LMA is defined by HUD as a means of achieving the Low-and-Moderate Income National Objective. In accordance with HUD's CPD Notice 19-02, the following applies:

Compiling a Service Area from the LMISD. HUD uses the term "Service Area" to define the entire area served by the project. The service area could be an entire community (ex: for a water tower project), a small area of the community (ex: replacement of several blocks of sewer lines), or a rural area that crosses several block groups (ex: rural water extension). Based on the type of activity, the applicant will identify the service area, and then refer to the LMISD for an equivalent geography.

Service areas are a singular area and based on the intended beneficiaries of the LMA activity. The service area must be drawn to include all of the locations affected by the project. Applications with more than one service area will be deemed Do Not Fund. The service area shall not be drawn to

intentionally include LMI persons that would not benefit, nor shall it be drawn to intentionally exclude non-LMI persons that would benefit. All service areas must include at least 5 homes or be a section (nominally one square mile as defined by the Public Land Survey System).

Once the service area has been reasonably delineated, the LMISD geographies that most closely correspond are chosen. Applicants may combine geographies to best represent service areas, typically by combining two or more block groups. When using multiple geographies in the determination of LMA compliance, applicants are reminded that percentages shall not be averaged across multiple geographies. The proper calculation is as follows:

$$\text{LMI \%} = (\text{LMI Persons Geography A} + \text{LMI Persons Geography B} + \text{LMI Persons Geography C...}) \div (\text{LMI Universe Geography A} + \text{LMI Universe Geography B} + \text{LMI Universe Geography C...})$$

Example. A service area corresponds with two block groups. Block group 1 is 54.17% LMI with a population of 325 LMI persons of 600 total persons. Block group 2 is 50% LMI and has 1,500 LMI persons of 3,000 total persons. If 54.17% and 50.00% are averaged, which would be incorrect, the result is 52.09% LMI. However, the correct calculation per the formula above is 1,825 persons divided by 3,600 persons, resulting in 50.69% LMI [which HUD does not allow to be rounded up to 51%].

$$(325 + 1,500) \div (600 + 3,000) = 50.69\% \text{ LMI}$$

Applicants should not define a single service area by compiling a mix of place and block group data. These geographic layers have overlapping areas. If a service area was constructed by mixing block group and place data, residents would likely be double-counted.

#### No Prorating

Applicants may not prorate the LMISD data when a given service area includes a portion of a geography from HUD's published datasets. The LMA determination shall be made based on the entirety of the data of the census geography which the service area both completely encloses and significantly overlaps. Using the standard LMISD geographies will usually result in a change to a custom service area, which is acceptable, provided that the two areas reasonably correspond to one another.

*Figure 3. Partial Overlay of a Service Area and LMISD Geographies.*

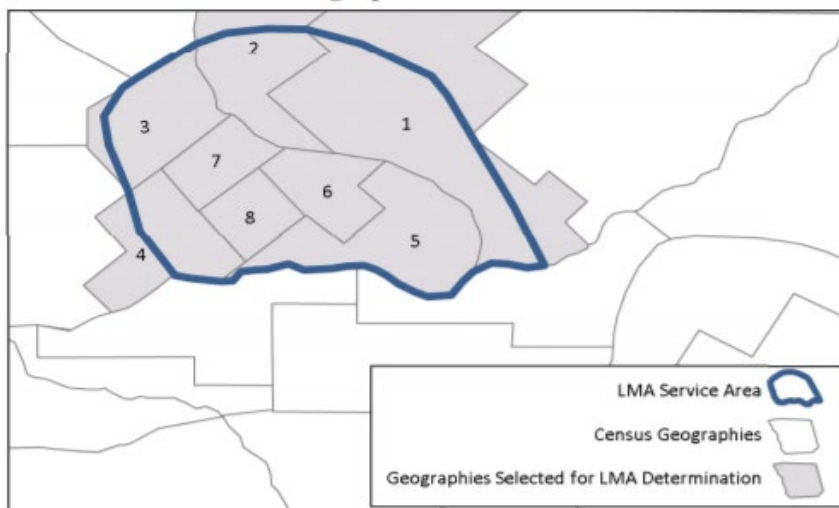

Example. In Figure 3, the LMA service area completely encloses geographies 5, 6, 7 and 8; additionally, geographies 1, 2, 3 and 4 are partially overlain by the service area. The entirety of the data for all geographies 1 through 8 must be included in the determination of LMA compliance to use the LMISD. The applicant shall not prorate geographies 1, 2, 3, or 4.

### a. Determining LMI Benefit

If the Community's LMI shown on LMISD or the LMI Data for Illinois Places is 51% or greater, no further action is needed, regardless of where the project is located in the Community or how many project areas are proposed. Utilizing Figure 3 above, assuming that the combination of gray areas was either a City, Village, Township or County, and the Service Area is the blue circle, the project would be eligible if the gray area (community) meets the 51% LMI threshold.

If the City, Village, Township or County does not meet 51% low-to-moderate income using LMISD or LMI Data, they may conduct an Income Survey only if:

- the HUD identified LMI percentage is 42% or greater; OR
- the HUD identified "margin of error (MOE)" when added to LMI identified by HUD would enable the community to reach "51%" LMI by conducting a survey.
  - For example, Community A is 41.2% LMI and has a MOE of +/- 10.4%, the highest LMI a survey could result in is 51.6%. Therefore, Community A could possibly meet 51% LMI and is eligible to conduct an income survey.
  - Community B is 41.2% LMI and has a MOE of +/- 4.8% the highest LMI survey could result is 46%. Therefore, it is not possible for Community B to meet 51% LMI and they are ineligible to conduct an income survey.

**If the LMI percentage or percentage plus MOE qualifies for an income survey, you will only survey the service area. If the service area is the whole community, the whole community must be surveyed. You do not survey the related geographies outside of the service area that helped to establish the baseline for income survey qualification. Using Figure 3 again, you will need to survey only the area contained within the blue lines of the ovoid shape.**

The listing of Illinois communities on DCEO's website shows HUD calculated LMI percentage and the applicable MOEs. To see the MOE on the LMISD tool, you must scroll down on the data block, however, LMISD does not provide MOE for all geographies.

#### SPECIAL CIRCUMSTANCES:

- If the project is confined to a smaller area inside of a City, Village, Township or County, and the Community does not meet 51%, LMI may be established utilizing Census Tract Block Group (or multiple contiguous blocks if the project is contained therein) data.
  - If a singular Census Block reaches 51% then there is no need to survey. If it reaches 42%, OR the "margin of error (MOE)" identified by HUD would enable the Census Block to reach "51%" LMI by conducting a survey; you may survey the Service Area
  - If the project covers multiple Census Blocks, use the Low-to-Moderate-Income Blending Worksheet in Section III, Part J. to calculate the percentage. If the calculation reaches 51% then there is no need to survey. If it reaches 42%, you may survey the Service Area.
- If the Community-wide projects benefit direct-billed water or sewer customers outside their corporate boundaries, then they will not have to account for those customers for LMI threshold purposes if utilizing LMISD or LMI Data for Illinois Places to establish the threshold of 51%. This is because they are likely already included in the data. However, if a survey is being utilized to establish LMI, they must be included in the survey.



- If a municipality sells services to another municipality, both the selling municipality and the buying (or proposed buying) municipality's LMISD must be included and documented. The overall HUD census LMI benefit of the selling and buying municipalities would be determined by the following formula: total low-mod residents of all municipalities divided by total population of all municipalities multiplied by 100 (Total LM Persons/Total Universe X 100 = LMI%). If residents along the route between the selling and proposed buying municipality are to be hooked up to the line, they must be surveyed and their data included in the above calculation.

#### b. Documenting LMI Benefit

**Applicants who meet the LMI threshold using HUD's LMISD tool must include a print-out of the LMISD area search result(s) and any worksheets showing the calculations used to determine the LMI percentage for the project area in the grant application.** In addition, the LMISD area used must correspond with the area identified on the project location map. CDBG staff reserves the right to not complete the review and deny funding if the LMI service area and the area identified on the project location map do not correspond. All LMI percentages will be verified as part of the review process. **CDBG staff reserves the right to not complete the review and deny funding, based on this threshold.**

Income Surveys -- The standardized income survey form (Contained in Section VII) required by the Department includes all essential questions needed for the CDBG application. This standardized format is to be used when submitting an income survey unless prior approval is received. Surveys may be conducted door-to-door or by mail. The Department will not approve the use of a telephone survey. Income Surveys must be completed based on the household occupants and include the structure address. The resident does not need to sign the Income Survey, however, residents receiving a direct benefit will need to complete an Income Certification prior to receiving benefit.

The number and percentage of LMI individuals derived from the local survey must be determined by the number of persons in the household utilizing HUD's CDBG Income Limits. These limits can be found at [CPD Income Eligibility Calculator and Income Limits - HUD Exchange](#). These figures are different for each county in the State. Once the survey has been completed, use the Income Survey Worksheet to tabulate the LMI percentage. Enter the data as required on the "Analysis of Amount of Funds Used to Benefit Low-to-Moderate Income Persons" form. Maintain the survey forms on file. It is important to maintain the documentation in order to verify the survey results. "Spoiled Surveys" should not be included in your survey results. The Department will consider a survey to be "spoiled" under the following conditions: answers that are "whited" out; answers that are crossed through; or surveys that are not completed with one writing instrument consistently throughout (e.g., blue ink, pencil, etc.).

- **Conducting an Income Survey** -- In order to conduct an eligible Income Survey, the applicant must attempt to survey 100 percent of the households in the service area and must receive at least a 75 percent response rate of usable surveys. Incomplete or incorrectly completed surveys are not considered usable. Income surveys must be completed after the deadline for the previous round of funding. Surveys completed prior to January 18, 2024 will not be accepted.

Applicants must use the Income Survey Worksheet (Contained in Section III, Part J) to document the LMI benefit.

- **If conducting a Survey in a service area that cannot be qualified by LMISD in accordance with HUD CPD Notice 19-02, an income survey map must be included in the application.** The survey map should detail all households in the service area indicating "higher" income,

“lower” income, vacant, and no response, as well as all non-residential buildings in the benefit-area (businesses, schools, churches, and government facilities). Please see Section III, F, 1 for details on mapping.

The households identified on the income survey map must total and exactly match the breakouts indicated on the Income Survey Worksheet:

Total Households in Area (High Income + Low Income + No Response);

Total Households Surveyed (High Income + Low Income);

Total LMI Households Surveyed (Low Income); and

Total Households Surveyed above LMI (High Income)

- **An income survey map is not necessary for a community-wide survey.** If funded, you must provide documentation from the U.S. Census Bureau to document the number of households.

**CDBG staff reserves the right to not complete the review and deny funding, based on this threshold, when the minimum Low-to-Moderate Income percentage has not been met.**

## 2. Documentation of Threat to Health and Safety:

A serious threat to health and safety is defined as a deficiency in the community public facility; the community lacks the facility entirely; problems clearly attributable to the deficiency have occurred, such as serious illness, disease outbreak, or serious environmental pollution; and the problem is present, continual, and chronic as opposed to occasional, sporadic, or probable.

Within the Project Summary, each application should detail the public infrastructure needs to be addressed by the proposed project and the specific project activities to be undertaken. This narrative should include, as appropriate, the degree to which present conditions affect public health and safety, the severity and immediacy of the problem, and whether the proposed activities are necessary to comply with state or federal regulations.

In addition to the narrative in the Project Summary, applications must include multiple examples of documentation of the threat to health and safety relating to the project in the application. Listed below are examples of acceptable documentation of threat to health and safety. All documents must contain dates and when applicable, the location.

- Well water tests (minimum 25% sampling). Include a test result summary from the testing lab. Include map of tested locations.
- Pressure tests (PSI<20 is considered a threat). Include a map of testing locations.
- Court Order
- Letter from Attorney General
- Surface water tests with map
- Newspaper Articles, Conversations on Social Media, Print-outs of television or radio broadcasts.
- Boil orders, map of line breaks with dates and IEPA reference documentation.
- IEPA or US EPA violation letters or documentation.
- Court Consent Decree
- Photographs (must identify subject matter of the photograph and indicate date and location). **If subject matter, date and location are not included, we will not accept the photograph.**
- Water and sewer break log and map

- Current resident complaint letters in their own words, dated, with address and signature. “Form letters” that the resident just signs will not be accepted.

**NOTE: Lead or asbestos pipes, alone, are not considered a threat to health/safety.**

**Threat to Health & Safety documentation must be no more than two (2) years old.** If a violation notice from IEPA/US EPA is submitted as documentation, and is more than two years old, the applicant must submit a written explanation from the issuing-agency explaining the current status of the violation/threat to health and safety. *Documentation more than two years old may be submitted to document history of the problem, but will not be reviewed without current documentation to substantiate a current threat.*

An application in which a threat to health and safety is well documented includes multiple examples from the list above, and a narrative that clearly explains the threat, and why it is a threat. Please consider that DCEO staff are not on-site to see the issue, so the narrative and documentation must “tell the story”. Proper documentation includes more than one kind of document”.

**CDBG staff reserves the right to not complete the review and deny funding, based on this threshold, when the threat to health and safety has not been documented or demonstrated.**

3. **Water and Sewer Rates:** A fundamental principle of utility fund financing is that user **rates should be sufficient** to fund the entire cost of utility system operations. This principle is accepted by all authoritative Sources. Therefore, **an applicant must demonstrate that the applicable Water or Sewer rate currently meets or exceeds 1 percent of the Median Household Income (MHI) per 5,000 gallons.** Water rates apply to proposed water projects, and sewer rates apply to proposed sewer projects. **Water, sewer, and/or any other type of municipal rates (e.g., trash service) may not be combined** to meet a sufficient water rate for a proposed water project or sewer rate for a proposed sewer project. Minimum allowable utility rates for Illinois municipalities can be found on the Department’s website at: <https://dceo.illinois.gov/communitydevelopment.html> Variable and combined utility rates are not acceptable.

The Utility Rate threshold does not apply to storm sewer, combined sewer separation, or drainage projects.

**CDBG staff reserves the right to not complete the review and deny funding, based on this threshold, when the minimum utility rate has not been met.**

## D. **FUNDING SOURCES**

Points will be assessed for communities contributing other funding toward construction costs of the proposed project. Applications must provide written evidence that necessary, additional funding for the project is firmly committed. If proper documentation is not provided, points will not be assessed. **Applicants are strongly cautioned to investigate all funding sources and make a firm decision as to the source prior to submitting a CDBG application.** Documentation necessary to provide evidence of additional funding includes:

- American Rescue Plan Act (ARPA) funds can be utilized by local governments for improvements in water and sewer infrastructure. The applicant’s council or board resolution committing a specific dollar amount of ARPA funds to the project must be included.
- A current firm commitment letter from a FINANCIAL INSTITUTION must include: language which indicates that the loan will be approved and that the institution will lend subject to certain conditions; the specific dollar amount of the loan; the specific term of the loan (**not to exceed 10 years, and no balloon or adjustable rate language**); and the projected interest rate of the loan. The date of the commitment letter cannot be more than 12 months prior to application date.
- For projects which intend to secure funding from the ILLINOIS ENVIRONMENTAL PROTECTION AGENCY (IEPA), the CDBG application must include a copy of and be listed on the IEPA Intended Funding List effective July 1<sup>st</sup> of the most recent year OR include a copy of an IEPA Letter of Commitment of funding. **NOTE: IEPA must be included in the CDBG Public Infrastructure grant application if it is to be used for construction costs of the project.**
- For projects which intend to secure bonds through the ILLINOIS FINANCE AUTHORITY (IFA), a copy of the Preliminary Resolution issued by IFA to indicate approval of the community’s application for bond funds must be submitted.
- A firm commitment of funding from the UNITED STATES DEPARTMENT OF AGRICULTURE RURAL DEVELOPMENT (RD) must include all pages of an approved Form RD 1940-1, “Request for Obligation of Funds.” Loan and grant funds are available with loans up to 38 years with interest rates generally 5 percent or lower.
- Units of Local Government proposing to use local sources (cash-on-hand, bonds, in-kind labor, or on behalf of utilities), must submit the following documentation, per source:
  - LOCAL CASH ON HAND – The applicant’s council or board resolution that committed a specific dollar amount to the project, which identifies where the monies will be paid or received from, must be included.
  - ISSUE REVENUE OR GENERAL OBLIGATION BONDS – The applicant’s council or board resolution approving the intent to issue bonds and specify a dollar amount.
  - IN-KIND LABOR - the application must include 1) a “schedule” which details the activities to be completed by its employees, their titles, qualifications, hourly wages, and the projected number of hours needed to complete the activity to calculate the value of the in-kind labor; and 2) the applicant’s Resolution Committing In-Kind Labor identifying the activities and value of the labor.
  - ON BEHALF OF UTILITIES - The on behalf of utility’s council or board resolution committing a specific dollar amount to the project, which identifies where the monies will be paid or received from, must be included.
- For Applicants identifying IL CAPITAL PROJECTS as the fund source, an internal review will be conducted by the Department to verify that the project is fully-approved; including an executed Grant Agreement; all conditions have been met; final Business Enterprise Program clearance has been obtained (if applicable); and that the initial sanctioned-percentage of funds has been disbursed.

## E. NARRATIVE RESPONSES

All applications must include the following narrative responses as well as the requested documentation. See the Application Checklist contained in Section III, Part J for placement in the application.

1. **Letter of Transmittal** – must be on applicant’s official letterhead, dated, include the amount requested, a brief project description, the LMI benefit, and additional funding amount and source; and certify that the application meets the eligibility thresholds of Benefit to Low-to-Moderate Income Persons and Threat to Health and Safety; and, if not for a community-wide benefit, the project will benefit a service-area that is primarily residential. “On behalf of” applications for a Public Utility, System, Cooperative or District, must indicated the application is ”on behalf of” and for whom in the Transmittal Letter.
  
2. **Project Summary** – should consist of a narrative covering all key points of the proposed project *to be funded, in part or in full, with CDBG grant funds*. This summary should include the following:
  - Describe the project – What is being proposed (i.e. what specific construction activities and at what locations will they occur) and why? What threat to health & safety is being addressed? How long has the problem existed?
  - Describe the project area, including legal boundaries. Who is being affected and how? Indicate whether the project will have a community-wide or service-area benefit. Provide a detailed explanation of how this specific project area was determined.
  - The project structure (i.e., will the residents be direct customers of the water district or is an agreement needed, what is the applicant’s source of water, who will treat wastewater, etc.).
  - If an “on behalf of” application, indicate the Public Utility, System, Cooperative or District that the application is on behalf of.
  - The degree to which present conditions affect public health and safety.
  - The severity and immediacy of the problem.
  - Whether the project is necessary to comply with state or federal regulations.
  - Justification of the local government's need for CDBG assistance in relation to its overall financial capability, including discussion of outstanding indebtedness.
  
3. **Project Readiness Summary** – Each application must demonstrate that the proposed project is appropriate and achievable and that all actions have been completed to ensure timely implementation of the project. Each item below **MUST** be SPECIFICALLY addressed.
  - IEPA construction permit(s) - Indicate Status of permit. If not applicable, an explanation is required;
  - Right-of-Way - The community must have full control of the right-of-way either by having 100 percent of the necessary private property easements signed or a right-of-way docket. If eminent domain is required to execute a Private Property Easement as previously identified, proof of court approval of the eminent domain must be included in the application. Address the need for and current status of easements.

- Water/wastewater treatment agreement – If the applicant purchases water then an agreement should be in place and a copy included in the application. If not applicable, an explanation is required;
- Property Ownership/Option To Purchase - Identify the ownership of any property needed to complete the project (including option to purchase); and verify that the project will be shovel-ready; Applicant must own the property or agreements must be in place and included as documentation in the grant application. If option to purchase is not necessary, an explanation is required;
- Additional funding commitment(s) – Address all additional funding commitments, in narrative form. If no additional funds will be committed, an explanation is required;
- Status of written permission from railroad(s), county highway commissioners, IDOT, etc. to proceed with any railroad and/or road borings that are proposed; If written permissions are not necessary for the completion of the project, an explanation is required.

## F. INCLUSIONS

1. **Project Maps** - The following maps must be included in the application submission.

Please place maps larger than 8.5 x 11 inches at the back of the application, number them accordingly as to where they are located, and state those later page #'s on the map's "Page Number" field of the Application Submission Checklist.

- **A project location map** must be included in the application. It is expected to be sufficiently detailed to show the following information: 1) specific boundaries of the project area; 2) all integral components of the system being improved or constructed, including water tower, well, pump stations, existing water/sewer mains, proposed water/sewer mains, flow schematics, etc.; 3) railroads, highways, interstates, towns/cities/villages (rural projects), county lines, and corporate limits. The project map must be suitable for reproduction and shall not exceed the page size of 11 x 17 inches. (Applicants may also submit blueprints or larger project maps as a supplement to their submission, if they deem necessary in order to show project details sufficiently.)
- **A FEMA issued Floodplain map must** be included in the application. You can obtain this map by calling FEMA at 1(800) 358-9616 or by using the website <https://msc.fema.gov>. The exact project location must be clearly drawn on the FEMA map included in the application.
- **An income survey map** (If conducting an income survey to document LMI in a project area) **must** be included in the application. The survey map **must be a minimum of 11"x17"**, and clearly identify/detail all households in the project area indicating "higher" income, "lower" income, vacant, and no response, **as well as all non-residential buildings in the benefit-area (businesses, schools, churches, government facilities and miscellaneous structures including barns, sheds, and utility buildings).**

The following Key must be used when identifying ALL structures in the project area:

- ✦ High Income
- ★ Low Income
- Vacant

- ▲ No Response
- Businesses, schools, churches, government facilities
- ☒ Miscellaneous structures (barns, sheds, and utility buildings)

If a multi-unit residential building (e.g., apartment complex, duplex, town home, retirement center/apartments, homeless supportive housing with independent kitchen/dining area), is located in the project area, it should be identified as such and the number of units indicated on the map. Those units should be included in the “number of households” within the project area.

The **households** identified on the income survey map must total and exactly match the breakouts indicated on the Income Survey Worksheet:

Total Households in Area (High Income + Low Income + No Response);

Total Households Surveyed (High Income + Low Income);

Total LMI Households Surveyed (Low Income); and

Total Households Surveyed above LMI (High Income)

If a nursing home, college dormitory, or homeless shelter is located in the project area, it should be identified on the map, but not counted as a residential building, and a letter from the facility administrator included in the application. The letter may be obtained as documentation in lieu of surveying the residents individually. The letter must verify that the facility meets the HUD definition of a facility having a shared kitchen and dining facilities and must indicate the number of residents the facility accommodates. All of the residents are considered by HUD to be low income and would, therefore, be included in the survey results beginning on Line 14 of the Income Survey Worksheet. Please make a notation on the worksheet that this is being done. Retirement apartments, where residents have their own kitchens and dining areas, are not considered a "nursing home facility" and should be surveyed individually.

2. **Engineer’s Cost Estimate** (See Submission Checklist in Section III, Part J for placement.) Please keep in mind that it may be longer than one year from the time of application before the project is bid, and current costs might not be accurate at that time. Be certain to adjust costs based on estimated inflation. If it is difficult to make adjustments to individual project components, you may include an “Inflation Adjustment” line with an amount up to 10% of the total of current project construction costs.
  - Must be on company letterhead, include the date of the estimate and the engineer’s name.
  - Must be less than one year old from the date the application is due.
  - Must include a detailed breakdown of costs that match the costs contained on the CDBG GATA budget.
  - DO NOT include any Ineligible costs as identified in Section 3, Part B above, or miscellaneous, or contingency.
3. **Fair Housing Resolution** – All applicants are required to pass a Fair Housing Resolution to affirmatively further fair housing; post Fair Housing Posters; and make HUD Fair Housing Complaint forms available to the public. A copy of the Fair Housing Resolution must be submitted with the application.

## G. APPLICATION REVIEW AND EVALUATION PROCESS

The screening and review process for the program is designed to ensure that limited CDBG funds are awarded to communities that demonstrate the need for financial assistance and have a well-designed project. The actual number and types of awards will be subject to funding availability and the amount of each applicant's request.

The Department will review all applications as follows:

- Applications will be evaluated according to the Ranking Criteria described in Section H of the application guide.
- In cases where projects have identical overall ratings, applications benefiting the highest number of LMI persons will be considered first for funding.
- The Department reserves the right to perform a site visit.
- The following applications will be deemed “Do Not Fund” (DNF), not reviewed further nor considered for funding:
  - a. Applications for local governments that are not Grant Accountability and Transparency Act (GATA) registered and pre-qualified on the GATA Portal at <https://gata.illinois.gov> on the application due date.
  - b. Applications that do not meet the Citizen Participation requirements as outlined in Section II of the Guidebook.
  - c. Applications that do not clearly demonstrate and document 51.0 percent low-to-moderate income benefit to persons in the project area.
  - d. Applications that do not clearly demonstrate and document a threat to health and safety.
  - e. Applications in which the local government’s Water or Sewer (whichever is applicable to the project) rate does not currently meet or exceed 1 percent of the Median Household Income (MHI) per 5,000 gallons.
  - f. The type of infrastructure proposed requires an IEPA Construction Permit, and a copy of a non-expired IEPA Construction Permit is not included in the grant application, or the type of infrastructure proposed does not require an IEPA Construction Permit, but the applicant did not explain why the Permit is not required.
  - g. Applications in which the Private Property Easements form, indicating 100% signed, or a Right-of-Way Docket is not submitted, or if the necessity of easements is not addressed. If eminent domain is required to execute a Private Property Easement as previously identified, proof of court approval of the eminent domain must be included in the application or the project will be deemed “Do Not Fund”.
  - h. Applications for projects that have both a community-wide and a project-area benefit or that have multiple activity codes.
  - i. Applications for projects that appear to primarily benefit a business/commercial district.
  - j. Applications that do not designate an Administrating Entity and/or include the required contract and (if applicable) environmental form.



- k. Applications in which the Chief Elected official did not sign all appropriate documents as the Authorized Representative.
- l. Applications that contain forged or altered signatures or dates or in which non-CDBG forms are used (Section I of the Guidebook)
- m. Applications that have the following errors in relation to the Engineer's Cost Estimate:
  - i. Engineer's cost estimate not contained in application;
  - ii. Engineer's cost estimate not on company letterhead without engineer's name or not dated;
  - iii. Engineer's cost estimate does not include a detailed breakdown of costs;
  - iv. Engineer's cost estimate more than one year old from the application due date

All recommendations are forwarded to the Director of the Department who makes the final funding decisions. All decisions will be based on the general distribution of funds in Section I of the CDBG Guidebook.

## H. **RANKING CRITERIA**

Projects will be evaluated according to the criteria noted below.

1. **Opportunity Zones:** Illinois has 327 designated opportunity zones, all of which are low-income communities. To further encourage the investment in and vitality of these communities, three (3) points will be given to applicant communities with projects located within opportunity zones. For more information on Opportunity Zones, please see: <https://dceo.illinois.gov/oppzn.html>  

Opportunity Zone = 3 Points
2. **DCEO Underserved Area:** An "underserved area" is a census tract which meets one of the following four tests.
  - Poverty rate of at least 20%; or
  - 35% or more of the families with children in the area are living below 130% of the poverty line, according to the latest American Community Survey; or
  - At least 20% of the households in the area receive assistance under the Supplemental Nutrition Assistance Program (SNAP); or
  - Average unemployment rate that is more than 120% of the national unemployment average, for a period of at least two (2) consecutive calendar years preceding the date of the application.

Applicant communities with projects located within a designated underserved area will receive two (2) points. For more information and to identify an underserved area, please see: <https://dceo.illinois.gov/expandrelocate/incentives/underservedareas.html>  

Underserved Area = 2 Points
3. **Project Impact/Per Capita Cost:** In order to maximize the number of beneficiaries, points will be assigned according to the **grant funds requested per person served**. A maximum of ten

points will be assigned to projects requesting \$1,000 or less per person served. No points will be assigned to projects requesting \$5,000 or more per person. Points will be assigned as follows:

<u>Per Capita Cost</u>	<u>Points</u>
\$0 - \$1,000.99	10
\$1,001.00 - \$1,250.99	9
\$1,251.00 - \$1,500.99	8
\$1,501.00 - \$1,750.99	7
\$1,751.00 - \$2,000.99	6
\$2,001.00 - \$2,500.99	5
\$2,501.00 - \$3,000.99	4
\$3,001.00 - \$3,500.99	3
\$3,501.00 - \$4,000.99	2
\$4,001.00 - \$4,999.99	1
\$5,000.00 Plus	0

4. **Additional Funding:** Additional points will be assessed for communities contributing other construction funding toward the completion of the proposed project. A maximum of 10 points will be assigned to projects contributing 60% or more of the total construction costs. No points will be assigned to projects contributing less than 10% of the total construction costs. The breakout is as follows:

<b>POINTS</b>	<b>Percentage of Total Construction Costs Contributed</b>
<b>1</b>	At least 10% and up to 19.9 % of Total Construction Costs
<b>2</b>	At least 20% and up to 29.9 % of Total Construction Costs
<b>4</b>	At least 30% and up to 39.9 % of Total Construction Costs
<b>6</b>	At least 40% and up to 49.9 % of Total Construction Costs
<b>8</b>	At least 50% and up to 59.9 % of Total Construction Costs
<b>10</b>	At least 60% or over of Total Construction Costs

No points will be assessed if all appropriate documentation (outlined in Section 3, Part D) is not included.

5. **Threat to Health & Safety/Urgency (25 percent of overall score):** The degree to which present conditions affect public health and safety, and the severity and immediacy of the problem **must be demonstrated in the documentation**. Points received will be allocated on the following criteria (**maximum 25 points**). **No points will be allocated if proper documentation is not included in the application.** See C2 of the Guidebook for examples.

- **Imminent threat of entire system failure (25 points)**

*Example:*

- Well pumps broken and parts are no longer manufactured; using stand by pumps.
- Court order (must be directly related to the project)
- Consent decree
- Raw sewage in water source
- Consistent, systematic water pressure less than 20 PSI (not related to breaks)

- **Imminent failure in a specific area** that does not affect the entire system, but does have a negative impact on a portion of the system, and which **will result in total failure, or a complete interruption in service**, if not addressed. (20 points)

*Example:*

- Same as above, but in a service area
- Collapsed Water/Sewer Line

- **Project should be completed as soon as possible** (15 points)

*Example:*

- Radon found in water supply.
- Serious IEPA violation/s (must be directly related to the project)
- Collapsed sewer line
- Excessive water main breaks or boil orders (10+ within 6 months)
- Large percentage of private wells containing coliform (75-100% of sampling)
- Leaky water tower that is affecting water pressure

- **Project is not urgent, but needs to be completed in short term** (10 points)

*Example:*

- Private wells having unacceptable levels of coliform (50-75% of sampling)
- Frequent water main breaks or boil orders (2-9 within one year)
- EPA non-compliance letter (must be directly related to the project)
- Infill and inflow into sewers
- Water pressure less than 20 PSI (depending on severity)
- Leaky water tower

- **Project can be completed in the next few years** (5 points)

*Example:*

- Over-utilized water source
- Low water pressure (but higher than 20 psi)

6. **Project Administration (20 percent of overall score)** A professional Grant Administrator with a proven track record is an important resource for completing a successful CDBG project. The track record of a Grant Administration Entity will be evaluated by examining all open CDBG grants on the application deadline date. Calculations will be made to provide DCEO staff the overall average percentage of funds drawn on open grants of each Grant Administration Entity. “Entity” includes all persons permanently employed by or temporarily contracted to complete grant administration work for the firm.

Points will be assessed on the average draw-down percentage as follows:

<u>Average Drawdown Percentage</u>	<u>Points</u>
80% or more drawn	= 20 points
70 – 79.9% drawn	= 16 points
60 – 69.9% drawn	= 14 points
50 – 59.9% drawn	= 12 points
40 – 49.9% drawn	= 8 points
30 – 39.9% drawn	= 4 points
20 – 29.9% drawn	= 2 points
Less than 20% drawn	= 0 points

7. **Project Readiness (30 percent of overall score):** Each application must demonstrate that the proposed project is appropriate and achievable and that all actions required have been completed to ensure timely implementation of the project. If the application is funded, any action not completed at the time of application will be included in the Notice of State Award Finalist (NOSAF) as a special grant condition. All applicants will start with the **maximum 30 points**. If any actions are not completed, deductions will be made on the following requirements:

- If applicable, a copy of an executed agreement for the purchase of water or wastewater treatment, signed and dated by all parties, must be in place. If not included, not addressed, or unclear, -10 points.
- If applicable, a valid copy of an option to purchase land. (Option must include price, date option expires and seller's signature). If not submitted, not addressed, or unclear, -10 points.
- Copy of Project Location Map. If not submitted or if the project activities are not clearly drawn on the project map, -5 points.
- Copy of Floodplain Map indicating project location(s). If not submitted, or the project is not drawn on the map, -5 points.
- The percentage goal for minority contractors must meet or exceed the percentage of minorities residing in the project's community. (Information to be provided on the Minority Benefit/Affirmative Housing Statement contained in Section III, Part J). If the form is incomplete, not included, or the minority percentage is not met, -2 points.
- Fair Housing Resolution - A Fair Housing Resolution must be adopted/in place. If not included, -5 points.

**Deductions Made for Clerical Errors:** Applications will receive a 5-point deduction in the area of Project Readiness for each of the following situations, deficiencies: (-5 each)

- Inconsistencies exist throughout the application. Examples:
  - i. The cover letter indicates "sewer project" and the summary indicates water project extension.
  - ii. Narrative information is for "Community A" when the application is submitted for "Community B").
  - iii. The project costs or total funds requested differ between the cover letter, CDBG GATA budget, Engineer's cost estimate, and the project information form.
- The project summary is vague and the reviewer cannot determine what the project is or how the problem will be addressed and/or the project completed.
- Forms are not completed in their entirety, i.e., missing dates, signatures, general contact information, etc.
- The FEIN, UEI #, or other identifying codes contained in the application are not assigned to the applicant or responsible entity.
- The "Copy" file required for application submission does not contain all documents as the "Original", **or** (if included in original) does not contain color copies of documents.
- The application contains evidence of pre-scoring.

## I. SUBMISSION INFORMATION

Under the Grant Accountability & Transparency Act (GATA), all applicants must register with the State of Illinois via the “Grantee Portal” at [www.grants.illinois.gov](http://www.grants.illinois.gov) and be pre-qualified prior to submitting an application. Applications submitted by communities who have not registered, been pre-qualified, or completed the ICQ for the current year **will not be considered for review**.

In cooperation with GATA, please submit the following as part of your CDBG grant application package:

- **State of Illinois Uniform Grant Application**  
Available at: <https://dceo.illinois.gov/communitydevelopment.html> Uniform Grant Application – Program Matters Contact Information should contain the grant writer’s contact information; Business/Administrative Matters Contact Information should contain the contact information of the person fiscally responsible for the grant (clerk, Treasurer, etc.); and information on the Authorized Representative must be the Chief Elected Official, who must also sign the application.
- **State of Illinois CDBG Uniform Budget Template**  
Available at: <https://dceo.illinois.gov/communitydevelopment.html>. Uniform Budget must match the the Engineer’s Cost Estimate.
- **IRS Certification Letter**  
Include in the application “Letter 147c” or “Letter 4158c” provided by the IRS to verify the Taxpayer Identification Number (TIN) or Federal Employer Identification Number (FEIN) for the applicant. If you do not have a current (dated within five years) copy of an IRS certification letter on file, please call the IRS Business line, **1-800-829-0115**, to request a “**Letter 147C**”, or call **1-877-829-5500** to request a “**Letter 4158c**.” Only the applicant is authorized to request a copy of this letter.
- **W-9 Form**  
Include a completed W-9 form. The name of the entity must exactly match the name indicated on the IRS certification letter, and the W-9 must be the most current issued (<https://www.irs.gov/pub/irs-pdf/fw9.pdf>).
- **SAM Registration/UEI (Unique Entity ID) #**  
All grantees, sub-recipients and contractors participating in the CDBG Program are required to be registered in the System for Award Management (SAM) at [www.sam.gov](http://www.sam.gov) for the purpose of obtaining a Commercial or Government Entity (CAGE) Code. The CAGE Code is a unique identifier assigned to government agencies and various organizations. UEI numbers provide a standardized method of identifying a given facility at a specific location. **This documentation, for the applicant, must be submitted with the application.**

All applicants should complete the application package and submit an original and copy of all requested material to the Department's **Springfield** Office at:

**In Person:**

Illinois Department of Commerce and Economic Opportunity  
Office of Community Development  
1020 South Spring Street  
Springfield, IL 62704

**Or mailed to:**

Illinois Department of Commerce and Economic Opportunity  
Office of Community Development  
1011 South 2<sup>nd</sup> Street  
Springfield, IL 62704

Applications must be received by **Wednesday, December 4, 2024, no later than 5:00 p.m.** Facsimile and e-mailed submissions will **not** be accepted.

### **PACKAGING YOUR APPLICATION**

All grant application materials **must** be:

- Typed (except for signatures and maps)
- Clipped together with a large binder clip on the top.
- Any oversize pages such as maps should be placed at the end of the application. State those later page #'s for oversized pages in the related item's "Page Number" field on the Application Submission Checklist page.
- Contained in two brown legal-size (will accommodate 8½" x 14" papers), open-top (no foldovers with cords or ties) expandable folders (One marked "original," and one marked "copy")
- Brown legal size folders are to be labeled with a 2"x 4" white label, placed in the top right-hand corner of the folder with the following information:
  - Name of Applicant
  - 2025 Public Infrastructure
  - Original or Copy

For Example:

VILLAGE OF ABRACADABRA  
2025 Public Infrastructure  
Original

**DO NOT USE:** dividers, staples, binders, folders or other methods of containment.

**Submit the original and one complete copy.** *Be certain if there are documents in **color** in the original, that the copies are in **color** also!*

**SECTION III**  
**PUBLIC INFRASTRUCTURE**  
**J. APPLICATION FORMS**

*Template*  
**LETTER OF TRANSMITTAL**

*This information must be transferred to the Applicant Community's Official Letterhead*

Date

Director's Office  
Illinois Department of Commerce and Economic Opportunity  
607 East Adams  
Springfield, Illinois 62701

Dear Director:

The (name of local government) is submitting an application for a public infrastructure grant under the Community Development Block Grant (CDBG) program. The grant request is in the amount of \$(dollars) to be used to (use of funds). The benefit to low-to-moderate income individuals is (LMI)%. The (name of local government) will contribute \$(dollars) from (source of funds) toward the completion of the project. *(If applicable – This application is being submitted on behalf of (rural water system or cooperative, water or sanitary district, or an unincorporated area).*

I certify that this application meets the eligibility thresholds of Benefit to Low-to-moderate Income Persons, Threat to Health and Safety and that the community meets the required water or sewer rate. Further, if not proffering a community-wide benefit, this project will benefit a service-area that is primarily residential.

Very truly yours,

(Signature of Chief Elected Official)



**CDBG Public Infrastructure Application Submission Checklist**

All CDBG applications will be screened for completeness. Applicants must complete and submit this checklist with the application. **All pages of the application must be sequentially numbered.** Use the right-hand column, labeled "Page Number" to indicate the page for each item. (.)

Both the original grant application (*indicate "original" on the cover*) and a complete copy (*indicate "copy" on the cover*) of the grant application must be submitted. See Section III I for submission information.

PROJECT INFORMATION

PAGE NUMBER

_____	Letter of Transmittal from Chief Elected Official	_____
_____	Completed Submission Checklist (This Page)	_____
_____	State of Illinois DCEO Uniform Grant Application (See Section VII)	_____
_____	CDBG Applicant Project Information	_____
_____	Project Summary (See Section III E)	_____
_____	Project Readiness Summary (See Section III E)	_____
_____	FEMA Issued Floodplain Map (See Section III F)	_____
_____	Project Maps (See Section III F )	_____
_____	State of Illinois Uniform Budget Template (See Section VII)	_____
_____	Engineer's Cost Estimate (See Section III F )	_____
_____	Private Property Easements or Right-of-Way Docket (See Section III H )	_____
_____	LMISD Area Benefit Printout(s) (See Section III C)	_____
_____	Low-to-Moderate-Income Blending Worksheet, if applicable (See Section III C)	_____
_____	Analysis of Low-to-Moderate Benefit (See Section III C)	_____
_____	Low-to-Moderate Income Survey Summary, if applicable (See Section III C)	_____
_____	Income Survey Worksheet, if applicable (See Section III C)	_____
_____	Income Survey Map, if applicable (See Section III F)	_____
_____	Minority Benefit/Affirmative Housing Statement (In Section VII)	_____
_____	CDBG Community Need/Project Benefit Determination (See Section III H)	_____

DOCUMENTATION, CERTIFICATIONS, RESOLUTIONS

**Citizen Participation: 7-Day Notice/Public Hearings (See Section IIC, Sample In Section VII)**

_____	_____Newspaper clipping _____Publisher's certification _____Certified minutes _____Attendance sheet(s)	_____
_____	Council Resolution of Support <b>or</b> Resolution of Support and Commitment of Local Funds (Template in Section VII) ( <i>If using local funds, you MUST indicate the account the funds are in</i> )	_____
_____	Local Government Certifications (In Section VII)	_____
_____	Mandatory Disclosures (In Section VII)	_____
_____	Conflict of Interest Disclosure (In Section VII)	_____
_____	Intergovernmental Cooperation Agreement, if applicable (In Section VII)	_____
_____	Signed Contract for provision of Activity Delivery, (In Section II)	_____
_____	Completed Exempt-CENST-ER-Format form, if applicable (In Section II)	_____

ATTACHMENTS

_____	Health & Safety Documentation (See Section III C)	_____
_____	Firm documentation of commitment from other funding source(s) (See Section III D)	_____
_____	Copy of IEPA Construction Permit(s) (See Section III G)	_____
_____	Copy of water purchase or wastewater treatment agreement (if applicable) (See Section III H )	_____
_____	Copy of Option to Purchase (if applicable) (See Section III H)	_____
_____	Fair Housing Ordinance/Resolution (See Section III F)	_____
_____	W-9 (See Section III I)	_____
_____	SAM Registration (UEI #) (See Section III I)	_____
_____	IRS Certification Letter (See Section III I)	_____
_____	GATA Registration Printout (See Section III I)	_____
_____	Oversized Maps (if applicable)	_____

**STATE OF ILLINOIS – DCEO UNIFORM GRANT APPLICATION**

*(See Section VII for Form Information)*

**NOTES on the UNIFORM APPLICATION FOR STATE GRANT ASSISTANCE:**

- The name and contact information for Program/Project Matters (lines 23-30) should be the person who wrote the application.
- The name and contact information for the Business/Administrative Office (lines 31-38) should be the financial representative for the local government (City Treasurer, Clerk or other person responsible for financial accuracy of local government accounts).
- The authorized representative (lines 45-53) must be the Chief Elected Official.

**CDBG APPLICANT PROJECT INFORMATION  
PUBLIC INFRASTRUCTURE**

*Type of Project (see Section III A for definitions)*

- 03I Flood & Drainage Improvements (includes storm sewers)**
- 03Jw Water Improvements**
- 03Js Sewer Improvements**

*If this project is “on behalf of” another entity, name of entity:* \_\_\_\_\_

**I. PROJECT BENEFIT INFORMATION** - Provide the following for **all** Public Infrastructure projects:

- Census - HUD LMISD Area
- Community Wide Survey
- Service-Area Survey

**CENSUS TRACT(s) and /BLOCK GROUP NUMBER(s) – Use additional sheet, if necessary.**

TOTAL NUMBER OF PERSONS SERVED

TOTAL NUMBER OF LMI PERSONS SERVED

PERCENT BENEFIT TO LMI PERSONS

**PROJECT LOCATION (Adress of a building within the project benefit area):**

\_\_\_\_\_

**The project location will be utilized to verify inclusion in an an opportunity zone and/or DCEO underserved area.**

**II. APPLICANT INFORMATION**

Fiscal Year End Date: \_\_\_\_\_MM/\_\_\_\_\_DD

NOTES on the UNIFORM APPLICATION FOR STATE GRANT ASSISTANCE:

- The name and contact information for Program/Project Matters (lines 23-30) should be the person who wrote the application.
- The name and contact information for the Business/Administrative Office (lines 31-38) should be the financial representative for the local government (City Treasurer, Clerk or other person responsible for financial accuracy of local government accounts).
- The authorized representative (lines 45-53) must be the Chief Elected Official.

**III. GRANT ADMINISTRATOR FOR THIS PROJECT**

First Name			
Last Name			
Title			
Agency Name			
Agency Type			
Mailing Address			
Telephone		Email	
Federal Employer Identification Number			
RACF ID Number			

**IV. PROJECT ENGINEER**

First Name			
Last Name			
Title			
Agency Name			
Agency Type			
Mailing Address			
Telephone		Email	
Federal Employer Identification Number			

**PROJECT SUMMARY**  
*(See Section III E)*

**PROJECT READINESS SUMMARY**  
*(See Section III E)*

**FEMA ISSUED FLOODPLAIN MAP**  
*(See Section III F)*

## **PROJECT MAPS**

*(See Section III F )*



**STATE OF ILLINOIS – UNIFORM BUDGET TEMPLATE**

*(See Section VII for Form Information)*

**ENGINEER'S COST ESTIMATE**  
*(See Section III F )*

### PRIVATE PROPERTY EASEMENTS

**Total Number of Easements Needed** \_\_\_\_\_

**Total Number of Easements Signed** \_\_\_\_\_

**Percentage of Easements Signed\*** \_\_\_\_\_

\*If less than 100 percent of necessary easements are signed or a Right-of-Way docket is not provided, the project will be deemed “Do Not Fund”.

<b>Name</b>	<b>Address</b>	<b>Easement Signed</b>
<i>Jane Doe – SAMPLE –</i>	<i>123 Main Street</i>	<i>X</i>

**LMISD AREA BENEFIT PRINTOUT(S)**

**Please Note: HUD is currently updating LMISD online and it is unknown when it will be available. If unavailable when application is submitted, you will need to use and we will verify eligibility via HUD's Dataset. A copy of this dataset is available on our website.**

**LOW-to-MODERATE INCOME BLENDING WORKSHEET**  
 (To Be Used to Blend LMI Data from Multiple HUD Census Geographies and/or LMI Surveys)

**Complete One Set of Fields for Each Block Group of a Census Tract (or Census Place) Covered by Proposed Project**

**Source 1**

Place Name or Group/Tract# \_\_\_\_\_  
 County \_\_\_\_\_  
 State 17 (Illinois) \_\_\_\_\_  
 LOWMOD Persons \_\_\_\_\_  
 LOWMOD Universe \_\_\_\_\_

**Source 2**

Place Name or Group/Tract# \_\_\_\_\_  
 County \_\_\_\_\_  
 State 17 (Illinois) \_\_\_\_\_  
 LOWMOD Persons \_\_\_\_\_  
 LOWMOD Universe \_\_\_\_\_

**Source 3**

Place Name or Group/Tract# \_\_\_\_\_  
 County \_\_\_\_\_  
 State 17 (Illinois) \_\_\_\_\_  
 LOWMOD Persons \_\_\_\_\_  
 LOWMOD Universe \_\_\_\_\_

**Source 4**

Place Name or Group/Tract# \_\_\_\_\_  
 County \_\_\_\_\_  
 State 17 (Illinois) \_\_\_\_\_  
 LOWMOD Persons \_\_\_\_\_  
 LOWMOD Universe \_\_\_\_\_

**Source 5**

Place Name or Group/Tract# \_\_\_\_\_  
 County \_\_\_\_\_  
 State 17 (Illinois) \_\_\_\_\_  
 LOWMOD Persons \_\_\_\_\_  
 LOWMOD Universe \_\_\_\_\_

**Source 6**

Place Name or Group/Tract# \_\_\_\_\_  
 County \_\_\_\_\_  
 State 17 (Illinois) \_\_\_\_\_  
 LOWMOD Persons \_\_\_\_\_  
 LOWMOD Universe \_\_\_\_\_

**Total LOWMOD Persons:** \_\_\_\_\_

**Total LOWMOD Universe:** \_\_\_\_\_

**Blended LMI Calculation:**

**Total LOWMOD Persons:** \_\_\_\_\_ ÷ **Total of LOWMOD Universe:** \_\_\_\_\_ × 100

**= Combined LMI Percentage of Entire Proposed Project Area:** \_\_\_\_\_ % (two decimal points)

**ANALYSIS OF BENEFIT TO LOW-TO-MODERATE INCOME PERSONS**

Activity*	Total # of Persons Activity Will Serve <i>(Survey Worksheet – Line 16)</i>	# of Low - Moderate Income Persons Activity Will Serve <i>(Survey Worksheet – Line 14)</i>	% of Persons Served who have Low - Moderate Income <i>(Survey Worksheet – Line 17)</i>	Amount of CDBG Funds Requested for the Activity	Amount of CDBG Funds to Benefit Low - Moderate Income Persons

**Methodology**

Please check the appropriate box below.

1.  U. S. Census Data calculated by HUD (LMISD):
2.  Community/Service-Area Income Survey: The entire (100%) population of the community or service area must be surveyed with a minimum 75% usable survey response rate.

\*Each major activity should be detailed separately when the number of persons benefiting varies from activity to activity. Low-to-moderate income connections would be an example of an activity that should be detailed separately.

Applicant Name: \_\_\_\_\_

**LOW-TO-MODERATE INCOME SURVEY  
SUMMARY**

This summary form must be completed by all applicants undertaking an income survey to determine low-to-moderate income (LMI) benefit. Include the appropriate Survey Worksheets.

Income surveys must be completed after the deadline for the previous round of funding. Surveys completed prior to January 20, 2023 will not be accepted. All surveys must include the address but the name or signature of the occupant is not necessary. All income survey must be reviewed, signed and dated by the reviewer.

1. Date(s) Survey Data Collected: \_\_\_\_\_

2. Survey Type:  All (100%) of Community  
 All (100%) of Service Area

**Community Wide/Service Area Survey**

3. Are the completed survey questionnaires on file with the applicant?

Yes       No      If "No," please explain:

\_\_\_\_\_

\_\_\_\_\_

4. Indicate who conducted the survey and how it was conducted (e.g., door-to-door, mailing):

\_\_\_\_\_

\_\_\_\_\_

Applicant Certification:

\_\_\_\_\_  
Signature of Authorized Official

\_\_\_\_\_  
Date

Applicant: \_\_\_\_\_

Date(s) survey conducted: \_\_\_\_\_

Survey Type: All (100%) of Community

All (100%) of Service Area

**INCOME SURVEY WORKSHEET**

**USE TO CALCULATE LOW-TO-MODERATE INCOME (LMI) PERCENTAGE  
USING HUD CDBG INCOME GUIDELINES**

This form is to be used for ALL income surveys.

**PART A. INFORMATION CONTAINED IN YOUR SURVEY (2 decimals)**

- |   |           |       |                                      |
|---|-----------|-------|--------------------------------------|
| 1. Enter the established total number of households in the service area.  | 1. _____. | _____ | <b>FOR<br/>DCEO<br/>USE<br/>ONLY</b> |
| 2. Enter the total number of households interviewed ( <b>valid responses</b> ).   | 2. _____. | _____ |                                      |
| 3. Enter the total number of low-to-moderate income households interviewed.   | 3. _____. | _____ |                                      |
| 4. Enter the total number of persons living in the low-to-moderate income households interviewed.                             | 4. _____. | _____ |                                      |
| 5. Enter the total number of households interviewed in which the income was above the low-to-moderate income level.           | 5. _____. | _____ |                                      |
| 6. Enter the total number of persons living in the households in which the income was above the low-to-moderate income level. | 6. _____. | _____ |                                      |

**PART B. CALCULATIONS BASED ON DATA CONTAINED IN SURVEY**

- |   |            |       |                                      |
|---|------------|-------|--------------------------------------|
| 7. If a Community-wide/service-area wide survey was conducted, divide line 2 by line 1. (This is the survey response rate. It should equal or exceed 75.0 percent.) | 7. _____.  | _____ | <b>FOR<br/>DCEO<br/>USE<br/>ONLY</b> |
| 8. Divide Line 4 by Line 3. (This is the average size of the LMI households you interviewed.)   | 8. _____.  | _____ |                                      |
| 9. Divide Line 6 by Line 5. (This is the average size of the non-LMI households you interviewed.)   | 9. _____.  | _____ |                                      |
| 10. Divide Line 3 by Line 2. (This is the proportion of households interviewed that have low-to-moderate incomes.)  | 10. _____. | _____ |                                      |
| 11. Divide Line 5 by Line 2. (This is the proportion of households interviewed that do not have low-to-moderate incomes.)   | 11. _____. | _____ |                                      |
| 12. Multiply Line 1 by Line 10 (This is the estimate of the total number of LMI households in your service area.)   | 12. _____. | _____ |                                      |



- |  |           |
|--|-----------|
| 13. Multiple Line 1 by Line 11. (This is the estimate of the total number of non-LMI households in your service area.)   | 13. _____ |
| 14. Multiply Line 8 by Line 12. (This is the estimate of the total number of LMI persons in your service area.)  | 14. _____ |
| 15. Multiply Line 9 by Line 13. (This is the estimate of the total number of non-LMI persons in your service area.)  | 15. _____ |
| 16. Add Line 14 and Line 15. (This is the estimate of the total number of persons in your service area.)   | 16. _____ |
| 17. Divide Line 14 by Line 16, and multiply the resulting decimal by 100. (This is the estimated percentage of persons in your service area who have low-to-moderate incomes). | 17. _____ |

### PART C. INSTRUCTIONS AND EXPLANATIONS

1. Round all numbers to two decimal places (XX.XX)
2. Line 1 should equal the total number of households identified as low income, high income, and no response.
3. When you are completing Part A, be sure that the answers are logical. For example, the number on Line 4 cannot be smaller than the number on Line 3 (because every household must have at least one person.) Similarly, the number on Line 6 cannot be less than the number on Line 5. Also note that the number on Line 3 plus the number on Line 5 should equal the number on Line 2 -- every household is either low-to-moderate or it is not.
4. Some examples for Part B. For purposes of illustration, assume that you estimated that the service area contained 650 households (Line 1). Assume that you conducted the survey and interviewed 250 households (Line 2), of whom 130 had low-to-moderate incomes (Line 3). These low-to-moderate income households contained 450 persons (Line 4). The 120 households with incomes over the low-to-moderate incomes (Line 5) contained 400 persons (Line 6.). You would complete Part B as follows:

- |         |  |
|---------|--|
| Line 8  | If the households you interview contained 450 low-to-moderate persons in 130 households, the number on Line 8 would be about 3.46 (450/130).       |
| Line 9  | If the households you interviewed contained 400 non-low-to-moderate persons in 120 households, the number on Line 9 would be about 3.33 (400/120). |
| Line 10 | If you interviewed a total of 250 households, 130 of which had low-to-moderate incomes, the number on Line 10 would be about .52 (130/250)         |
| Line 11 | If 120 of the 250 households interviewed did not have low-to-moderate incomes, the number on line 11 would be about .48 (120/250)                  |

- Line 12 If your service area contained an estimated 650 households, and you interviewed 250, of which 130 had low-to-moderate incomes, the number on Line 12 would be about 338 (650 X .52).
- Line 13 Continuing with the example, Line 13 would be about 312 (650 X .48).
- Line 14 3.46 persons per LMI household times 338 LMI households -- Line 14 would be about 1,169.
- Line 15 3.33 persons per non-LMI household times 312 non-LMI households -- Line 15 would be about 1,039.
- Line 16 Total LMI persons (1,169) plus total non-LMI persons (1,039) -- Line 16 would be about 2,208 estimated total persons.
- Line 17 1,169 LMI persons divided by 2,208 total persons yields about .5294. Multiplied by 100, this gives an estimate that 52.94 percent of the residents have low-to-moderate incomes.

NOTE: If a nursing home, college dormitory, or homeless shelter is located in the project area, it should be identified on the map, but not counted as a residential building, and a letter from the facility administrator included in the application. The letter may be obtained as documentation in lieu of surveying the nursing home residents individually. The letter must verify that the facility meets the HUD definition of a facility having a shared kitchen and dining facilities and must indicate the number of residents the facility accommodates. All of the residents are considered by HUD to be low income and would, therefore, be included in the survey results beginning on Line 14 of the Income Survey Worksheet. Please make a notation the worksheet that these residents are being included. Retirement apartments, where residents have their own kitchens and dining areas, are not considered a "nursing home facility" and should be surveyed individually.

**INCOME SURVEY MAP (if applicable)**  
*(See Section III F)*

**MINORITY BENEFIT/AFFIRMATIVE HOUSING STATEMENT**

*(See Section VII for Form)*

### CDBG COMMUNITY NEED/PROJECT BENEFIT DETERMINATION

Please provide the following information relative to the project for which CDBG funds are being requested:

- a Total Project Cost: \$ \_\_\_\_\_
- b CDBG Grant Requested: \$ \_\_\_\_\_
- c Total # of Persons Served: # \_\_\_\_\_
- d Line b divided by Line c \$ \_\_\_\_\_ (cost per capita)
- e Monthly charge for 5,000 gallons of water and 5,000 gallons of sewage treatment

Water Charge \$ \_\_\_\_\_ /5,000 gallons

Sewer Charge \$ \_\_\_\_\_ /5,000 gallons

If actual rates are not available, please provide PROJECTED rates.

(If water/sewer billed in cubic feet, provide the cost based upon 669 cubic feet.)

Provide dates of most recent rate changes

Water rate change: \_\_\_\_ / \_\_\_\_ / \_\_\_\_

Sewer rate change: \_\_\_\_ / \_\_\_\_ / \_\_\_\_

Population according to the most recent Census.

- f Please identify the Census year: \_\_\_\_\_

- g Provide both figures even though your application applies to only one

Current number of water and sewer accounts:

Total Water Accounts: \_\_\_\_\_ Total Sewer Accounts: \_\_\_\_\_

Residential Water Accounts: \_\_\_\_\_ Residential Sewer Accounts: \_\_\_\_\_

Estimated number of NEW residential water and sewer accounts:

New Residential Water Accounts: \_\_\_\_\_

New Residential Sewer Accounts: \_\_\_\_\_

Total Customers Outside Corporate Limits: \_\_\_\_\_

Residential Customers Outside Corporate Limits: \_\_\_\_\_

**PUBLIC HEARING NOTICE**

*(See Section VII for Sample)*

**NEWSPAPER CLIPPING**  
*(See Section II C)*

**PUBLISHER'S CERTIFICATION**  
*(See Section II C)*



**CERTIFIED MINUTES**

*(See Section II C)*

**ATTENDANCE SHEET(S)**  
*(See Section II C)*

**COUNCIL RESOLUTION OF SUPPORT**

*(See Section VII for Template)*

**LOCAL GOVERNMENT CERTIFICATIONS**

*(See Section VII for Form)*

## **MANDATORY DISCLOSURES**

*(See Section VII for Form)*

**CONFLICT OF INTEREST DISCLOSURE**

*(See Section VII for Form)*

## **INTERGOVERNMENTAL COOPERATION AGREEMENT**

*(See Section VII for Form if Applicable)*

**SIGNED CONTRACT FOR PROVISION OF ACTIVITY DELIVERY**  
*(See Section II)*



**COMPLETED EXEMPT-CENST-ER-FORMAT FORM**  
*(for CDBG-funded Activity Delivery only, See Section II)*

**HEALTH & SAFETY DOCUMENTATION**  
*(See Section III C)*

**FIRM DOCUMENTATION OF COMMITMENT FROM  
OTHER FUNDING SOURCE(S)**  
*(See Section III D)*

**COPY OF IEPA CONSTRUCTION PERMIT(S)**  
*(See Section III G )*

**COPY OF WATER PURCHASE or  
WASTEWATER TREATMENT AGREEMENT (if applicable)**  
*(See Section III H)*

**COPY OF OPTION TO PURCHASE (if applicable)**  
*(See Section III H)*

**FAIR HOUSING ORDINANCE/RESOLUTION**  
*(See Section III F)*

**W-9**  
*(See Section III I)*



**SAM REGISTRATION (UEI #)**  
*(See Section III I)*

**IRS CERTIFICATION LETTER**  
*(See Section III I)*

**GATA REGISTRATION PRINTOUT**  
*(See Section III I)*

**OVERSIZED MAPS (if applicable)**



**SECTION VII  
STANDARD DOCUMENTS and INFORMATION**

**STATE OF ILLINOIS – DCEO UNIFORM GRANT APPLICATION**[Community Development - Community Development \(illinois.gov\)](https://illinois.gov)

- The name and contact information for Program/Project Matters (lines 23-30) should be the person who wrote the application.
- The name and contact information for the Business/Administrative Office (lines 31-38) should be the financial representative for the local government (City Treasurer, Clerk or other person responsible for financial accuracy of local government accounts).
- The authorized representative (lines 45-53) must be the Chief Elected Official.

## STATE OF ILLINOIS – UNIFORM BUDGET TEMPLATE

[Community Development - Community Development \(illinois.gov\)](#)

### MINORITY BENEFIT/AFFIRMATIVE HOUSING STATEMENT

a. What is the percentage of the minority group(s) population residing in the community or the community <u>nearest</u> the proposed service area?	%
Identify the characteristics of the population of the project area by specific ethnic group. This information may be obtained from the most recent Census Data for the “applicant community.” If submitting an “on behalf of” application for a project in an unincorporated area, use Census Data for the project’s County.	

Racial Group	Total Persons	# of Hispanic / Latino Ethnicity
White		
Black/African American		
Asian		
American Indian/Alaskan Native		
Native Hawaiian/Other Pacific Islander		
American Indian/Alaskan Native and White		
Asian and White		
Black/African American and White		
American Indian/Alaskan Native and Black/African American		
Other Individuals Reporting more than One Race		
# of Female Headed Households		

With the <u>exception</u> of "Female Heads of Households", the above numbers should equal the total number of persons to benefit from the project service area.	
b. What is the goal for the percentage of CDBG funded contracts to be awarded to minority contractors?	%
c. If the percentage goal in <i>b</i> is <u>substantially less</u> than the percentage of minorities residing in the community, please explain. _____	

d. The applicant agrees to affirmatively further fair housing by posting Fair Housing Posters and by making HUD Fair Housing Complaint Forms available to the public. In addition, the unit of local government <input type="checkbox"/> Already has a Fair Housing Resolution on file. (Indicate Number and Date Passed _____) <input type="checkbox"/> If funded, will pass a Fair Housing Resolution.
---

**Signature of Chief Elected Official:** \_\_\_\_\_

**Date** \_\_\_\_\_



**Sample**  
**PUBLIC HEARING NOTICE**

***Reasonable access to all available application materials must be provided where all persons within the community will have reasonable access (e.g., Village or City Hall or a public area such as a post office, web page, community center, bank, etc. located within the same community as the applicant) and shall be available for a reasonable amount of time to allow for response and comment.***

(Applicant) will hold a public hearing on (date), at (time), in (place) to provide interested parties an opportunity to express their views on the proposed federal funded Community Development Block Grant (CDBG) project. Persons with disabilities or non-English speaking persons who wish to attend the public hearing and need assistance should contact (name, address, and phone #) no later than (date). Every effort will be made to make reasonable accommodations for these persons.

On or about (date of application submission), (Applicant) intends to apply to the Illinois Department of Commerce and Economic Opportunity for a grant from the State CDBG program. This program is funded by Title 1 of the federal Housing and Community Development Act of 1974, as amended. These funds are to be used for a community development project that will include the following activities: (summary of proposed project). The total amount of CDBG funds to be requested is \$(Amount requesting). The amount of CDBG funds proposed to be used for activities that will benefit low-to-moderate income persons is \$(amount of CDBG funds requested X percentage of low-to-moderate income persons). The (Applicant) also proposes to expend \$(amount) in non-CDBG funds on the project. These non-CDBG funds will be derived from the following sources: (source(s) and amount).

Information related to this project will be available for review prior to the public hearing as of (date of publication) at the office (location within the community) between the hours of (office hours). Interested citizens are invited to provide comments regarding these issues either at the public hearing or by prior written statement. Written comments should be submitted to (name and address—this may be the community or the application writer) no later than (date of public hearing) in order to ensure placement of such comments in the official record of the public hearing proceedings. A plan to minimize displacement and provide assistance to those displaced has been prepared by (Applicant) and is also available to the public. This project will result in (no displacement of any persons or businesses – or – displacement of the following persons and businesses [name and address]). For additional information concerning the proposed project, please contact (name, telephone number) or write to (person, address).

**Sample**  
**COUNCIL RESOLUTION OF SUPPORT**

Resolution No. \_\_\_\_\_

(The Resolution **CANNOT** be dated prior to the date of the Public Hearing)

WHEREAS, the (unit of local government) is applying to the State of Illinois for a Community Development Block Grant, and

WHEREAS, it is necessary that an application be made and agreements entered into with the State of Illinois.

NOW, THEREFORE, BE IT RESOLVED as follows:

- 1) that the (unit of local government) apply for a grant under the terms and conditions of the State of Illinois and shall enter into and agree to the understandings and assurances contained in said application.
- 2) that the Mayor (County Board Chairman) and City Clerk (County Clerk) on behalf of the City (County) execute such documents and all other documents necessary for the carrying out of said application.
- 3) that the Mayor (County Board Chairman) and City Clerk (County Clerk) are authorized to provide such additional information as may be required to accomplish the obtaining of such grant.

Passed this \_\_\_\_\_ day of \_\_\_\_\_, \_\_\_\_\_. (date required)

ATTEST: \_\_\_\_\_  
City Clerk (County Clerk) Mayor (County Board Chairman)

**Sample**  
**RESOLUTION OF SUPPORT AND COMMITMENT OF LOCAL FUNDS**

**(The Resolution CANNOT be dated prior to the date of the Public Hearing)**

WHEREAS, the City (County) of (unit of local government), is applying to the State of Illinois for a Community Development Block Grant (CDBG) grant,

WHEREAS, it is necessary that an application be made and agreements be entered into with the State of Illinois, and

WHEREAS, cost of the project are such that financial participation by the grantee is necessary in conjunction with CDBG funds.

NOW, THEREFORE, BE IT RESOLVED as follows:

- 1) that the City (County) apply for a grant under the terms and conditions of the State of Illinois and shall enter into and agree to the understandings and assurances contained in said application.
- 2) that the Mayor (County Board Chairman) and City Clerk (County Clerk) on behalf of the City (County) execute such documents and all other documents necessary for the carrying out of said application.
- 3) that the Mayor (County Board Chairman) and City Clerk (County Clerk) are authorized to provide such additional information as may be required to accomplish the obtaining of such grant.
- 4) that the City (County) of (unit of local government) does hereby commit funds from **(account/fund/source)** in the amount of \$(dollars) for use in conjunction with an Illinois Community Development Block Grant, for an estimated total project cost of \$(dollars).

Passed this (x) day of (month), (year) (date required)

\_\_\_\_\_  
 Mayor (County Board Chairman)

ATTEST:

\_\_\_\_\_  
 City Clerk (County Clerk)

## LOCAL GOVERNMENT CERTIFICATIONS

On this (date) of (month), (year), the (title and name of the Chief Elected Official) of (name of the local government) hereby certifies to the Department of Commerce and Economic Opportunity in regard to an application and award of funds through the Community Development Block Grant that:

1. It will comply with the National Environmental Policy Act (NEPA) with the submission of this application and it further certifies that no aspect of the project for assistance has or shall commence prior to the award of funds to the community and the receipt of an environmental clearance.
2. It will comply with the Interagency Wetland Policy Act of 1989 including the development of a plan to minimize adverse impacts on wetlands, or providing written evidence that the proposed project will not have an adverse impact on a wetland.
3. It will comply with the Illinois Endangered Species Protection Act and the Illinois Natural Area Preservation Act by completing the consultation process with the Endangered Species Consultation Program of the Illinois Department of Natural Resources, or providing written evidence that the proposed project is exempt.
4. It will identify and document all appropriate permits necessary to the proposed project, including, but not limited to: building, construction, zoning, subdivision, IEPA and IDOT.
5. No legal actions are underway or being contemplated that would significantly impact the capacity of the (name of local government) to effectively administer the program, and to fulfill the requirements of the CDBG program.
6. It will coordinate with the County Soil and Water Conservation District regarding standards for surface and sub-surface (tile) drainage restoration and erosion control in the fulfillment of any project utilizing CDBG funds and involving construction.
7. It is understood that the obligation of the State will cease immediately without penalty of further payment being required if in any fiscal year the Illinois General Assembly or federal funding source fails to appropriate or otherwise make available sufficient funds for this agreement.
8. It acknowledges the applicability of Davis-Bacon prevailing wage rate requirements to construction projects; a wage rate determination must be obtained prior to commencement of any construction or equipment installation; and, it shall discuss these requirements with the contractor.
9. It will comply with Section 3 of the Housing and Urban Development Act of 1968 to ensure that employment and other economic opportunities generated by certain HUD financial assistance shall, to the greatest extent feasible, and consistent with existing federal, state, and local laws and regulations, be directed to low and very low income persons and businesses.
10. It certifies that no occupied or vacant occupiable low-to-moderate income dwellings will be demolished or converted to a use other than low-to-moderate income housing as a direct result of activities assisted with funds provided under the Housing and Community Development Act of 1974, as amended.
11. It will conduct a Section 504 self-evaluation of its policies and practices to determine whether its employment opportunities and services are accessible to persons with disabilities.
12. It will comply with 2 CFR 200, 24 CFR 570, Part 85, 24 CFR 58, and the Illinois' Grant Accountability and Transparency Act (GATA).
13. **A FEMA Floodplain map is included in the application (as required) and is located on Page \_\_\_\_\_.**

---

Signature of Chief Elected Official

Date

## MANDATORY DISCLOSURES

Award applicants and recipients of awards from the State of Illinois (collectively referred to herein as “Grantee”) must disclose, in a timely manner and in writing to the State awarding agency, all violations of State or federal criminal law involving fraud, bribery, or gratuity violations potentially affecting the award. See 30 ILCS 708/40; 44 Ill. Admin Code § 7000.40(b)(4); 2 CFR § 200.113. Failure to make the required disclosures may result in remedial action.

Please describe all violations of State or federal criminal law involving fraud, bribery, or gratuity violations potentially affecting the awarding of a grant to your organization:

Grantee has a continuing duty to disclose to the Department of Commerce and Economic Opportunity (the “Department”) all violations of criminal law involving fraud, bribery or gratuity violations potentially affecting this grant award.

By signing this document, below, as the duly authorized representative of the Grantee, I hereby certify that:

- All of the statements in this Mandatory Disclosure form are true, complete and accurate to the best of my knowledge. I am aware that any false, fictitious, or fraudulent statements or claims may subject me to criminal, civil or administrative penalties. (U.S. Code, Title 18, Section 1001).
- There is no action, suit or proceeding at law or in equity pending, nor to the best of Grantee’s knowledge, threatened, against or affecting the Grantee, before any court or before any governmental or administrative agency, which will have a material adverse effect on the performance required by the grant award.
- Grantee is not currently operating under or subject to any cease and desist order, or subject to any informal or formal regulatory action, and, to the best of the Grantee’s knowledge, it is not currently the subject of any investigation by any state or federal regulatory, law enforcement or legal authority.
- If Grantee becomes the subject of an action, suit or proceeding at law or in equity that would have a material adverse effect on the performance required by an award, or an investigation by any state or federal regulatory, law enforcement or legal authority, Grantee shall promptly notify the Department in writing.

Grantee Organization: **Company Name**

By: \_\_\_\_\_  
Signature of Authorized Representative

Printed Name: **Authorized Signator Name**

Printed Title: **Authorized Signator Title**

Date:

## CONFLICT OF INTEREST DISCLOSURE

Award applicants and recipients of awards from the State of Illinois (collectively referred to herein as “Grantee”) must disclose in writing to the awarding State agency any actual or potential conflict of interest that could affect the State award for which the Grantee has applied or has received. See 30 ILCS 708/35; 44 Ill. Admin Code § 7000.40(b)(3); 2 CFR § 200.112. A conflict of interest exists if an organization’s officers, directors, agents, employees and/or their spouses or immediate family members use their position(s) for a purpose that is, or gives the appearance of, being motivated by a desire for a personal gain, financial or nonfinancial, whether direct or indirect, for themselves or others, particularly those with whom they have a family business or other close associations. In addition, the following conflict of interest standards apply to governmental and non-governmental entities.

- a. **Governmental Entity.** If the Grantee is a governmental entity, no officer or employee of the Grantee, member of its governing body or any other public official of the locality in which the award objectives will be carried out shall participate in any decision relating to a State award which affects his/her personal interest or the interest of any corporation, partnership or association in which he/she is directly or indirectly interested, or which affects the personal interest of a spouse or immediate family member, or has any financial interest, direct or indirect, in the work to be performed under the State award.
- b. **Non-governmental Entity.** If the Grantee is a non-governmental entity, no officer or employee of the Grantee shall participate in any decision relating to a State award which affects his/her personal interest or the interest of any corporation, partnership or association in which he/she is directly or indirectly interested, or which affects the personal interest of a spouse or immediate family member, or has any financial interest, direct or indirect, in the work to be performed under the State award.

The Grantee shall also establish safeguards, evidenced by policies, rules and/or bylaws, to prohibit employees or officers of Grantee from engaging in actions, which create or which appear to create a conflict of interest as described herein.

**The Grantee has a continuing duty to immediately notify the Department of Commerce and Economic Opportunity (the “Department”) in writing of any actual or potential conflict of interest, as well as any actions that create or which appear to create a conflict of interest.**

*Please describe all current potential conflict(s) of interest, as well as, any actions that create or which appear to create a conflict of interest related to the State award for which your organization has applied.*

If the Grantee provided information above regarding a current potential conflict of interest or any actions that create or appear to create a conflict of interest, the Grantee must immediately provide documentation to the applicable Department grant manager to support that the potential conflict of interest was appropriately handled by the Grantee’s organization. If at any later time, the Grantee becomes aware of any actual or potential conflict of interest, the Grantee must notify the Department’s grant manager immediately, and provide the same type of supporting documentation that describes how the conflict situation was or is being resolved.

Supporting documentation should include, but is not limited to, the following: the organization’s bylaws; a list of board members; board meeting minutes; procedures to safeguard against the appearance of personal gain by the organization’s

officers, directors, agents, and family members; procedures detailing the proper internal controls in place; timesheets documenting time spent on the award; and bid documents supporting the selection of the contractor involved in the conflict, if applicable.

By signing this document, below, as the duly authorized representative of Grantee, I hereby certify that:

- All of the statements in this Conflict of Interest Disclosure form are true, complete and accurate to the best of my knowledge. I am aware that any false, fictitious, or fraudulent statements or claims may subject me to criminal, civil or administrative penalties. (U.S. Code, Title 18, Section 1001).
- If I become aware of any situation that conflicts with any of the representations herein, or that might indicate a potential conflict of interest or create the appearance of a conflict of interest, I or another representative from my organization will immediately notify the Department’s grant manager for this award.
- I have read and I understand the requirements for the Conflict of Interest Disclosure set forth herein, and I acknowledge that my organization is bound by these requirements.

Grantee Organization: **Community Name**

By: \_\_\_\_\_  
Signature of Authorized Representative

Printed Name: **Authorized Signator Name**

Printed Title: **Authorized Signator Title**

Date:

**INTERGOVERNMENTAL COOPERATION AGREEMENT**

The (cooperative unit of local government), (county name) County, Illinois, seeks to support the efforts of the (applicant unit of local government) to obtain Community Development Block Grant (CDBG) funds from the Illinois Department of Commerce and Economic Opportunity for (proposed project) located in (project location community, township, county).

As the chief executives of our respective local governments, we are signing this agreement to cooperate as much as needed to accomplish these improvements.

The (applicant unit of local government) is hereby designated as the lead agency for this application and will be the applicant for the funds. The (applicant unit of local government) will be liable for all program administration functions should the grant be awarded.

\_\_\_\_\_

\_\_\_\_\_  
Attest

\_\_\_\_\_  
Attest

Date: \_\_\_\_\_

NOTE: This general form (or a suitable variation) is to be used by local government applicants whose proposed project or project area involves more than one jurisdiction. It is a required part of any "on behalf of" or joint application with appropriate modifications as may be required to fit local conditions.



## INCOME SURVEY COVER SHEET

**COMMUNITY DEVELOPMENT SURVEY**

Name of Community \_\_\_\_\_

Date \_\_\_\_\_

Interviewer's Name \_\_\_\_\_

Respondent's Street Address (Required):

\_\_\_\_\_  
Structure Number\_\_\_\_\_  
Street Name

Introduction: Hello, I'm \_\_\_\_\_ and I'm conducting a survey for the City/Village of \_\_\_\_\_. We're collecting information needed to complete an application for a community development grant. What you say will be kept strictly confidential in accordance with the Privacy Act of 1974 (Public Law 93-579). Your answers are very important to our community improvement effort.

**INSTRUCTIONS**

1. The Income Survey **must** include the physical address of the respondent, but it is not necessary for them to sign the Survey.
2. Complete all requested information based on the household occupants.
3. If the respondent wishes to not complete the "minority benefit determination" section of the Income Survey, the "I choose to not respond" box **must** be checked.
4. The original signature of the approver and date of review are required.
5. Surveys submitted without the occupant's address, date conducted, signature of approver and date approved will be considered spoiled/unusable. Further, verification of survey results may be randomly conducted by CDBG Program Staff.

*The Survey data will be used in the evaluation of the community development grant application. Completion of the Survey does not constitute an application for or guarantee assistance.*

**COMMUNITY DEVELOPMENT BLOCK GRANT INCOME SURVEY**

Community: \_\_\_\_\_ County: \_\_\_\_\_  
 Street Address: \_\_\_\_\_ Date Conducted: \_\_\_\_\_

1. How many people are living in the house? \_\_\_\_\_
2. Check here if female headed household ( ) \_\_\_\_\_
3. How many people are over 62 years old? \_\_\_\_\_
4. How many persons with physical or developmental disabilities are there in your household: \_\_\_\_\_
5. Do you own your own home? \_\_\_\_\_ Or rent? \_\_\_\_\_
6. To help determine the ethnic population of your locality or service area, please indicate the number of persons in the household in each appropriate category:

<b>MINORITY BENEFIT DETERMINATION</b>		
<b>Racial Group</b>	<b>Total Persons</b>	<b># of Hispanic / Latino Ethnicity</b>
White		
Black/ African American		
Asian		
American Indian/Alaskan Native		
Native Hawaiian/Other Pacific Islander		
American Indian/Alaskan Native and White		
Asian and White		
Black/African American and White		
American Indian/Alaskan Native and Black/African American		
Other Individuals Reporting more than One Race		
I choose to not respond <input type="checkbox"/>		

Use the most recent HUD CDBG Income Limits for your county. Indicate Month/Year: \_\_\_\_\_ (See Section IX Attachments)  
 Enter the figures detailed on the line entitled "LOW-INCOME" for 80% and "VERY LOW-INCOME" for 50%.

<b>Number of Persons in Family /Household</b>	<b>Annual Income Limit 30% of median (A)</b>	<b>Annual Income Limit 50% of median (B)</b>	<b>Annual Income Limit 80% of median (C)</b>
1			
2			
3			
4			
5			
6			
7			
8			

7. Based on the number of persons in your household, check whether your entire household income is:

**Lower** than Column A ..... \_\_\_\_\_      **Between** Columns B & C .... \_\_\_\_\_  
**Between** Columns A & B ..... \_\_\_\_\_      **Higher** than Column C ..... \_\_\_\_\_

COMMENTS

**FOR LOCAL OFFICE USE ONLY**

Type of Survey Conducted:  Door-to-Door     By Mail

\*REVIEW APPROVED BY:

Printed Name \_\_\_\_\_ Signature \_\_\_\_\_ Date \_\_\_\_\_  
 \*Surveys submitted without the occupant's address, date conducted, signature of approver and date approved will be considered spoiled/unusable. Further, verification of survey results may be randomly conducted by CDBG Program Staff

## CDBG HOUSING NEEDS GUIDE

SECTION A – MAJOR DEFICIENCIES	No Repair (0)	Repair (3)	Remove/Replace (6)
<b><u>Roofing</u></b>	<input type="checkbox"/>	<input type="checkbox"/>	<input type="checkbox"/>
Sagging, Buckling, Rotting Rafters			
Missing or Curling Shingles			
<b><u>Framing – Exterior Walls &amp; Sills</u></b>	<input type="checkbox"/>	<input type="checkbox"/>	<input type="checkbox"/>
Bulging or Leaning Walls			
Rotted or Deteriorated Framing			
<b><u>Framing – Load Bearing Beams</u></b>	<input type="checkbox"/>	<input type="checkbox"/>	<input type="checkbox"/>
Cracked or Sagging Beams & Joists			
<b><u>Foundation</u></b>	<input type="checkbox"/>	<input type="checkbox"/>	<input type="checkbox"/>
Settlement or Cracks in Load Bearing Walls			
Loose or Missing Foundation Materials			
<b><u>Furnace</u></b>	<input type="checkbox"/>	<input type="checkbox"/>	<input type="checkbox"/>
Adequate Heat to All Habitable Spaces			
<b><u>Plumbing – D W V</u></b>	<input type="checkbox"/>	<input type="checkbox"/>	<input type="checkbox"/>
System Properly Vented			
Unobstructed Drain Lines			
<b><u>Plumbing – Supply &amp; Fixtures</u></b>	<input type="checkbox"/>	<input type="checkbox"/>	<input type="checkbox"/>
Adequate Water Flow & Pressure			
Leaking Supply Lines			
<b><u>Electrical Service &amp; Distribution</u></b>	<input type="checkbox"/>	<input type="checkbox"/>	<input type="checkbox"/>
Sub-Standard Service Entry (mast & weatherhead)			
60 Amp or 110 - 2 Wire Service			
<b><u>Electrical Fixtures</u></b>	<input type="checkbox"/>	<input type="checkbox"/>	<input type="checkbox"/>
Inadequate Number of Receptacles & Switched Light Fixtures to Serve Household			
<b>SECTION B – MINOR DEFICIENCIES</b>	<b>No Repair (0)</b>	<b>Repair (2)</b>	<b>Remove/Replace (4)</b>
<b><u>Doors – Interior</u></b>	<input type="checkbox"/>	<input type="checkbox"/>	<input type="checkbox"/>
Missing doors, broken frames			
<b><u>Doors – Exterior</u></b>	<input type="checkbox"/>	<input type="checkbox"/>	<input type="checkbox"/>
Broken, Rotted Doors & Frames			
<b><u>Porches/Entrances</u></b>	<input type="checkbox"/>	<input type="checkbox"/>	<input type="checkbox"/>
Holes, Cracks or Rotting Materials			
Tilting or Sagging Components			
<b><u>Interior Flooring</u></b>	<input type="checkbox"/>	<input type="checkbox"/>	<input type="checkbox"/>
Holes or Tears in Floor Coverings			
<b><u>Windows</u></b>	<input type="checkbox"/>	<input type="checkbox"/>	<input type="checkbox"/>
Broken, Missing or Rotted Window Frames of Panes			
<b><u>Siding/Painting</u></b>	<input type="checkbox"/>	<input type="checkbox"/>	<input type="checkbox"/>
Deteriorated or Missing Siding			
Peeling or Chipping Paint			

For the purposes of creating three (3) cost estimates based on typical housing conditions, housing units being surveyed should be classified in the following three numerical categories.

**0–20**Points **Minimal** Rehabilitation Needed;**2–48**Points **Moderate** Rehabilitation Needed;**49–72**Points **Major** Rehabilitation Needed

## HOUSING REHABILITATION

### Required Public Notice Template

*(for local news publication for a one-week period)*

### Request for Qualifications (RFQ)

*The (Applicant community)*

### CDBG Housing Rehabilitation Grant

The *(Applicant community)* is soliciting proposals from qualified firms to provide grant-project managerial and administrative services to support the rehabilitation of housing units in *(Applicant community)*, Illinois.

The agreement will be a lump sum, fixed price based on the Budget Line Items of “General Administration” and/or “Rehabilitation Administration” (for inspection services). Payment terms will be negotiated with the selected firm.

Questions should be addressed to *Applicant community* at \_\_\_\_\_. Responses to this RFQ should be hand delivered to *Applicant community* or mailed to \_\_\_\_\_.

**Responses to this RFQ must be received no later than (date). Please state “Proposal for Management of CDBG Housing Rehabilitation Grant” on the cover.**

### PART ONE: SCOPE OF SERVICES

It is the *(Applicant community)* intent to select a firm to facilitate and oversee this comprehensive project’s scope of work, which consists of: (1) application intake and verification for program eligibility from local homeowners and (2) the inspections and subsequent rehabilitation of a projected number of housing units.

**The management project described by this RFQ is targeted to start by January 1, 2015 and to be completed by December 31, 2017.** All housing rehabilitation and related activities required to be performed under CDBG Housing Grant are targeted to start no later than 4-6 months from the beginning of the management project described in the RFQ and to be completed by no later than December 31, 2017.

The selected firm shall perform the following tasks if contracted to support the project described by this RFQ:

- Conduct **program marketing and outreach, application intake and verification of applicant eligibility** for homeowners, including to but not limited to total household income which meets HUD income guidelines for program eligibility, property ownership and any other eligibility requirements determined to be necessary.
- Provide **fiscal oversight of DCEO grant funds**, including but not limited to requests for draw down of necessary funds for all contractual payments (including administrative and rehabilitation contracts), submitting reports and supportive documentation to DCEO as described in the CDBG Housing Grant

Reports Deliverable Schedule and maintaining appropriate ledgers and accounting for the expenditure of all grant funds.

- **Solicit and maintain the participation of local, qualified General Contractors** that are licensed Lead Abatement Contractors. These duties include but are not limited to the verification of proper and current licensure and insurance for all participating general and sub-contractors in compliance with all Illinois Building Codes and Laws and DCEO Grant requirements.
- Document and ensure compliance with requirements necessary to comply with all applicable Local, State and Federal **building codes, environmental and health laws, applicable statutes and regulations, including the Illinois Lead Poisoning Prevention Act & Code which requires a licensed Lead Inspector/Risk Assessor to oversee compliance of the code.**
- Provide any **other necessary grant management support** to effectively and properly oversee this project and grant on behalf of the *(Applicant community)*.
- Prepare **cost estimates** for rehabilitation as described.
- Prepare **technical drawings, specification documents and all bid documents** to support the public bidding and procurement phase of the housing rehabilitation.
- Prepare a **General Conditions and Specifications Manual** for contractor's use which addresses all phases of housing rehabilitation – inspection and housing rehabilitation.
- Provide **managerial-field oversight during the housing rehabilitation phases** and prepare weekly field logs and maintain photo documentation of activities undertaken.

Respondent firms of organizations, and those firms with which the qualifying firm will subcontract under this project, must meet all permit and licensing requirements as specified by the *(Applicant community)*, the Illinois Department of Public Health (IDPH), the Illinois Department of Financial and Professional Regulation, the Illinois Environmental Protection Agency (IEPA) and the Illinois Historic Preservation Agency (IHPA).

All work shall comply with all applicable requirements of: the Illinois Lead based paint Poisoning Prevention Act & Code, the Illinois Environmental Protection Act and associated regulations promulgated thereunder, the Illinois Plumbing Code, the Illinois Roofing Code, the National Electrical Code, the NESHAP for asbestos, the Illinois Commercial and Public Building Asbestos Abatement Act 225 ILCS 207/1 and/or the Illinois Asbestos Abatement Act, 105 ILCS 105/1 in the handling of any regulated ACM or other asbestos-contaminated materials in the properties connected with this project, and any local building and zoning codes and ordinances adopted by the *(Applicant community)*, Illinois.

## PART TWO: REQUEST FOR QUALIFICATIONS –

### RESPONDENT INFORMATION NEEDED

#### Cover Page

The following information should be included under title, “**Proposal Submitted to the *(Applicant community)* for Management of the CDBG Housing Grant.**

1. Name of respondent

2. Respondent address
3. Respondent telephone number

### RFQ Contents

Interested respondents are invited to submit proposals that contain the following information. Respondents should letter and number their proposal response exactly as follows:

1. Introduction (transmittal letter)
2. Background / Experience / Knowledge
3. Staffing Resources / Firm's Capacity / Team Qualifications

A brief description of the above listed Proposal sections follows:

**1. Introduction (transmittal letter)**

By signing the letter, the Respondent certifies that the signatory is authorized to bind the Respondent. The Proposal response should include:

- a. A brief statement of the Respondent's understanding of the scope of work to be performed;
- b. A confirmation that the Respondent meets the appropriate State licensing requirements to practice in the State of Illinois;
- c. A confirmation that the Respondent has not had a record of substandard work within the last seven (7) years;
- d. A confirmation that the Respondent has not engaged in any unethical practices within the last seven (7) years;
- e. A confirmation that, if awarded the contract, the Respondent acknowledges its complete responsibility for the entire contract, including payment of any and all charges resulting from the contract;
- f. Any other information that the Respondent believes appropriate;
- g. The signature of an individual who is authorized to provide information of this nature in the name of the Respondent submitting the RFQ.

**2. Respondent's Background / Experience / Knowledge**

*If the Respondent is intending to partner or subcontract with another firm(s) with relevant experience, projects overseen by the partner / subcontractor firm(s) may be included in the Respondent's list of references or projects. The following information must also be provided for proposed partners / subcontractors.*

Respondents must provide the following, unless listed as optional:

- a. Describe Respondent's firm by providing its full legal name, date of establishment, type of entity and business expertise, short history, current ownership structure and any recent or materially significant proposed change in ownership. Include Respondent's federal tax identification number and name, title address, telephone number, fax number, and email

address of contact person authorized to contractually obligate the Respondent on behalf of the Respondent.

- b. Provide 3-5 client references for similar work completed in the last seven (7) years, including the names, phone numbers, and emails of contact persons in the organizations for any References. Respondent should include written references (letters or forms are acceptable) from private previous clients attesting to the quality of work and compliance with performance schedules Respondent cites in this section.
- c. Provide a list of 3 – 5 completed CDBG projects, detailing each project’s scope, each project’s budget (not the Respondent’s fee), each project’s location (city) and the Respondent’s scope of service provided. The projects should describe how the Respondent assisted each entity in managing a housing rehabilitation grant and project.
- d. Respondent should describe its knowledge of HUD requirements for the Community Development Block Grant Program.
- e. Respondent should describe its presence in Illinois. Specifically, if the Respondent is based exclusively in Illinois, it should state such; if the Respondent’s presence in Illinois is connected to specific engagements, it should briefly list and describe.
- f. Optional: Describe any issues the characteristics of which would be uniquely relevant in evaluating the experience of Respondent’s firm to handle the proposed project(s).

### 3. **Staffing Resources / Respondent’s Capacity / Team Qualifications**

Respondents must provide the following, unless listed as optional:

- a. Provide organizational chart for Respondent’s project team to support this contract, including any functions/positions to be supported by partners or subcontractors.
- b. Describe the firm’s existing workload and capacity to accomplish the work in the required time. Include any existing engagements, or awarded projects that may not have started, providing the contract term for each engagement.
- c. Estimate the number of FTE hours to be assigned to this project.
- d. Provide a list of staff members (or if currently not filled, the functions for proposed team members) who will be assigned to the project by the Respondent. Key management and field positions and functions providing the service described in Part One: Scope of Services, will generally include: (1) Principal in charge, President or Chief Executive Officer, (2) Project manager(s), (3) Licensed Lead Inspector/Risk Assessor Inspector(s), (4) Fiscal Manager and (5) Field Manager. Include staff that are or will be available at the start of the project and staff that will be hired or contracted by the Respondent if selected. If Respondent will utilize existing staff to support this project, please name these staff, their position and/or job function, and the number of hours the staff will be utilized on this project. If staff will be hired or contracted by the Respondent, contingent upon the Respondent being awarded this contract, please provide the names (if known), the job function and number of hours for each prospective hire that will be utilized on this project.
- e. Include resumes or curriculum vitae and license (for applicable functions) of each project team member identified above.

- f. Provide current information on professional liability coverage by Respondent's firm, including amount of coverage.
- g. Provide evidence of adequate financial stability through certified financial statements, including a balance sheet and income statement. The (Applicant community) reserves the right to request any additional information to assure itself of a Respondent's financial status.

### **PART THREE: SELECTION CRITERIA**

Firms requesting consideration for selection will be evaluated on the basis of written materials submitted and according to the following project related factors\*:

- ◆ Respondent's Experience and Qualifications (including any proposed partners or subcontractors). (30) points
- ◆ Respondent's Capacity and Team Resources. (35) points
- ◆ Respondent's Ability to meet the Project Schedule Requirements and Scope of Work (25) points
- ◆ \*Respondent Team's Proximity to the Project Site. (10) points

\* Geographic preference may be used as a selection factor for these services if there is adequate competition (two or more firms that are responsive and responsible).



## ECONOMIC DEVELOPMENT JOB CLASSIFICATIONS

- **Officials and Managers**

Classification includes administrative and managerial personnel who set broad policies, exercise overall responsibility for execution of these policies, and direct individual Departments or special phases of a firm's operation.

Includes: officials, executives, middle management, plant managers, department managers and superintendents, salaried supervisors who are members of management, purchasing agents and buyers, and kindred workers.

- **Professional**

Classification includes occupations requiring either college graduation or experience of such kind and amount as to provide a background comparable to college education.

Includes: accountants and auditors, architects, artists, chemists, designers, dietitians, editors, engineers, lawyers, librarians, mathematicians, natural scientists, registered professional nurses, personnel and labor relations specialists, physical scientists, physicians, social scientists, surveyors, teachers, and kindred spirits.

- **Technicians**

Occupations requiring a combination of basic scientific knowledge and manual skill which can be obtained through about 2 years of post-high school education, such as is offered in many technical institutes and junior colleges, or through equivalent on-the-job training.

Includes: computer programmers and operators, drafters, engineering aides, junior engineers, mathematical aides, licensed, practical or vocational nurses, photographers, radio operators, scientific assistants, technical illustrators, technicians (medical, dental, electronic, physical science), and kindred workers.

- **Sales**

Occupations engaging wholly or primarily in direct selling.

Includes: advertising agents and sales workers, insurance agents and brokers, real estate agents and brokers, stock and bond sales workers, demonstrators, sales workers and sales clerks, grocery clerks and cashier-checkers, and kindred workers.

- **Office and Clerical**

All clerical-type work regardless of level of difficulty, where the activities are predominantly non-manual, although some manual work not directly involved with altering or transporting the products is included.

Includes: bookkeepers, cashiers, collectors (bills and accounts), messengers and office helpers, office machine operators, shipping and receiving clerks, stenographers, typists and secretaries, telegraph and telephone operators, legal assistants, and kindred workers.

## JOB CLASSIFICATIONS CONTINUED

- **Craft Workers (Skilled)**

Manual workers of relatively high skill level having a thorough and comprehensive knowledge of the processes involved in their work. These workers exercise considerable independent judgment and usually receive an extensive period of training.

Includes: the building trades, hourly paid supervisors and lead operators who are not members of managements, mechanics and repairers, skilled machining occupations, compositors and typesetters, electricians, engravers, job setters (metal), motion picture projectionists, pattern and model makers, stationary engineers, tailors, arts occupations, hand painters, coaters, decorative workers, and kindred workers.

- **Operatives**

Workers who operate machine or processing equipment or perform other factory-type duties of intermediate skill level which can be mastered in a few weeks and require only limited training.

Includes: apprentices (auto mechanics, plumbers, bricklayers, carpenters, electricians, machinists, mechanics, building trades, metalworking trades, printing trades, etc); operatives, attendants (auto service and parking); blasters; chauffeurs; delivery workers; dressmakers and sewers (except factory); dryers; furnace workers; heaters (metal); laundry and dry cleaning operatives; milliners; mine operatives and laborers; motor operators; oilers and greasers (except auto); painters (except construction and maintenance); photographic process workers, stationary firefighters, truck and tractor drivers; weavers (textile); welders and flame cutters; inspectors; testers and graders; hand packers and packagers; and kindred workers.

- **Service Workers**

Workers in both protective and non-protective service occupations.

Includes; attendants (hospital and other institutions, professional and personal service, including nurses' aides and orderlies); barbers; cleaners; cooks (except household); counter and fountain workers; elevator operators; firefighters and fire protection workers; guards; door keepers; stewards; janitors; police officers and detectives; porters; servers; amusement and recreation facilities attendants; guides; ushers, public transportation attendants; and kindred workers.